



Get a free 2-year warranty



DE / FR / PT / SP



# GRAVITATIONAL BAND SAW PSR200AVE

IN GOOD HANDS

TRANSLATION OF ORIGINAL INSTRUCTION MANUAL



## WHO ARE WE?

**Peugeot Professional Tools** was born out of several obvious considerations.

The first was to combine the know-how of **Peugeot**, which has mastered the art of cutting since 1810, with the expertise of **Tivoly**, a metalworker since 1917, in order to create a wide range of machines and tools for construction and maintenance professionals.

It was also a natural step to want to serve craftsmen and small businesses driven by strong family and heritage values.

For these professionals, **Peugeot Outils Professionnels** offers machines and tools designed specifically for their needs. **These tools are reliable, durable, and can be repaired in France** and in countries under distribution agreements by local industrial and family partners.

Trustworthy equipment with a longer warranty, logistics, and

**French after-sales service.** The assurance of dealing with the people who assembled these tools and know every part that goes into them inside out.

From exceptional projects to everyday work, these tools are designed to withstand the most demanding conditions and stand the test of time.

**Peugeot Professional Tools** was born out of one obvious fact: that our tools are in good hands. The hands of those who work behind the scenes and give their all to satisfy their customers.

**Since 1810**, many things have changed, but the hands have remained the same. The hands of enthusiasts, craftsmen, dedicated technicians and installers, workers who are proud of themselves and their achievements.

**Peugeot Professional Tools: tools in good hands.**

## THANK YOU FOR YOUR PURCHASE.

We are delighted that you have chosen Peugeot Professional Tools. Every detail has been designed to offer you an exceptional experience, and we hope you enjoy using it as much as we enjoyed creating it for you.

Your trust is essential to us, and we are delighted to accompany you every step of the way in your experience with the Peugeot Professional Tools brand.

**Your purchase comes with a 2-year warranty, extendable to an additional 2 years.**





















To benefit from this, register at [www.peugeot-outils-pro.com](http://www.peugeot-outils-pro.com)

If you have any questions or need assistance, our team is available to provide you with the best possible service.

To contact our after-sales service, visit [www.peugeot-outils-pro.com](https://www.peugeot-outils-pro.com), call [+33\(0\)4.79.89.59.00](tel:+330479895900), or email [service@peugeot-outils-pro.com](mailto:service@peugeot-outils-pro.com).

Thank you for choosing Peugeot Professional Tools. Your satisfaction is our priority.

## SUMMARY

<b>1</b>	<b>INTRODUCTION</b> .....	<b>4</b>
<b>2</b>	<b>PICTOGRAMS</b> .....	<b>4</b>
2.1	MACHINE SAFETY PICTOGRAMS .....	4
2.2	PICTOGRAMS USED IN THIS INSTRUCTION MANUAL .....	4
<b>3</b>	<b>SAFETY</b> .....	<b>5</b>
3.1	GENERAL SAFETY REQUIREMENTS.....	5
3.2	SPECIFIC SAFETY REQUIREMENTS .....	6
3.3	OPERATOR PROTECTION .....	6
<b>4</b>	<b>DESCRIPTION AND OPERATION</b> .....	<b>7</b>
4.1	INTENDED USE OF THE MACHINE.....	7
4.2	CHARACTERISTICS .....	7
4.3	ACCESSORIES (OPTIONAL) .....	7
4.4	CONSUMABLES (OPTIONAL) .....	7
4.5	DESCRIPTION OF THE MACHINE.....	8
<b>5</b>	<b>INSTALLATION</b> .....	<b>9</b>
5.1	 PACKAGING .....	9
5.2	 HANDLING AND TRANSPORT .....	9
5.3	 SETTING UP THE MACHINE.....	9
5.4	 ASSEMBLY .....	9
5.5	 ELECTRICAL CONNECTION .....	11
5.6	 INITIAL TESTING AND INSPECTION BEFORE FIRST USE .....	11
<b>6</b>	<b>BAND</b> .....	<b>12</b>
6.1	 BAND RECOMMENDATION .....	12
6.2	 ASSEMBLY/DISASSEMBLY OF BAND .....	14
<b>7</b>	<b>USE</b> .....	<b>16</b>
7.1	 CONTROL DEVICES.....	16
7.2	 ADJUSTMENTS .....	17
7.3	 CUTTING FLUID.....	20
7.4	 POSITIONING OF PARTS IN THE VISE .....	20
7.5	 CUTTING PROCEDURE.....	21
7.6	 OPERATING INCIDENTS .....	22
7.7	 TABLE OF FAULTS AND SOLUTIONS .....	23
<b>8</b>	<b>MAINTENANCE</b> .....	<b>24</b>
8.1	 DAILY MAINTENANCE .....	24
8.2	 WEEKLY MAINTENANCE.....	24
8.3	 MONTHLY MAINTENANCE .....	24
8.4	 SEMI-ANNUAL MAINTENANCE.....	24
8.5	 ANNUAL MAINTENANCE .....	24
8.6	 MACHINE DECOMMISSIONING.....	24
<b>9</b>	<b>EXPLODED VIEW</b> .....	<b>25</b>
<b>10</b>	<b>ELECTRICAL DIAGRAM</b> .....	<b>29</b>
<b>11</b>	<b>NOISE LEVEL</b> .....	<b>30</b>
<b>12</b>	<b>ENVIRONMENTAL PROTECTION</b> .....	<b>31</b>
<b>13</b>	<b>WARRANTY</b> .....	<b>31</b>
<b>14</b>	<b>DECLARATION OF CONFORMITY</b> .....	<b>32</b>

## 1 INTRODUCTION



**For safety reasons, read these instructions carefully before using this machine.  
Failure to follow the instructions will result in damage to persons and/or the machine.**

This instruction manual is intended for the operator, adjuster, and maintenance technician.

This instruction manual is an important part of your equipment. It provides rules and guidelines that will help you use this machine safely and efficiently. You must familiarize yourself with the functions and operation by reading this instruction manual carefully. For your safety, it is particularly important that you read and observe all recommendations on the machine and in this instruction manual.

These recommendations must be strictly followed at all times when using and maintaining the machine. Failure to follow the safety guidelines and warnings in the instruction manual and on the machine and/or use other than that recommended in the instruction manual may result in machine failure and/or injury.

Please keep this instruction manual with the machine or in a place that is easily accessible at all times for future reference. Ensure that all personnel involved in the use of this machine can consult it periodically.

If the instruction manual is lost or damaged, please contact us or your dealer to obtain a new copy.

Always use PEUGEOT OUTILS PROFESSIONNELS components and parts. Replacing components or parts other than PEUGEOT OUTILS PROFESSIONNELS may cause damage to the machine and endanger the operator.

This manual describes the safety instructions to be followed by the user. It is the responsibility of the employer or user, in accordance with Article L.4122-1 of the Labor Code, to take care of their health and safety and that of other persons affected by their actions or omissions, in accordance, in particular, with the instructions given to them.

The employer must carry out an assessment of the specific risks associated with their activity, must train workers in the use of the machine and in the prevention of these risks, and must appropriately inform workers responsible for the use or maintenance of work equipment of the instructions or guidelines that apply to them.

## 2 PICTOGRAMS

### 2.1 MACHINE SAFETY PICTOGRAMS

Meaning of the safety pictograms affixed to the machine (keep them clean and replace them when they are illegible or detached):



Safety footwear must be worn.



Protective eyewear must be worn.



Wearing protective gloves is mandatory.



Read the instruction manual carefully.



Risk of crushing.



Electrical presence.



Ground connection for metal parts.



Hearing protection must be worn.



Do not wear loose clothing, wide sleeves, bracelets, watches, wedding rings, jewelry, ties, scarves, or any other items that could get caught in the moving parts of the machine.  
Wear hair nets for long hair.



Risk of debris and sparks caused by cutting.



Risk of cuts.



Direction of assembly and band feed.

### 2.2 PICTOGRAMS USED IN THIS INSTRUCTION MANUAL



Direct danger to persons and damage to the machine.



For band replacement and cleaning operations, wear protective eyewear and gloves.



Note.



Possible damage to the machine or its surroundings.



Minimum number of personnel required for certain operations.



If necessary, wear respiratory protection to reduce the risk of inhaling hazardous dust.



Technical skill level: operator, user.



Technical skill level: adjuster, maintenance.



Technical skill level: maintenance technician.



**Electrical work must be carried out by personnel who are qualified and authorized to perform low-voltage electrical work.**

### 3 SAFETY

#### 3.1 GENERAL SAFETY REQUIREMENTS



**To reduce the risk of fire, electric shock, mechanical shock, and personal injury when using power tools, follow basic safety precautions.**

This instruction manual only takes into account reasonably foreseeable behavior.

Our machines are designed and manufactured with operator safety in mind.

The machine must not be used by young workers under the age of 18.

We accept no liability for any damage caused by inexperience, incorrect use of the machine and/or damage to it and/or failure to comply with the instructions and safety rules contained in this instruction manual.

As a general rule, accidents always occur as a result of misuse or failure to read the instruction manual.

We remind you that any modification to the machine will result in our withdrawal of liability.

Check the presence, condition, and operation of all guards before starting work.

Ensure that moving parts are working properly, that there are no damaged components, and that the machine is operating perfectly during start-up.

Only competent and authorized personnel are permitted to repair or replace damaged parts.

Keep the work area clean and tidy.

Ensure that the entire work area is visible from the work position. Cluttered work areas and workbenches are a potential source of injury.

Do not use the machine outdoors or in very humid conditions. Reserve it for indoor use in a dry, well-ventilated area free from flammable liquids or gases.

Position the machine in a sufficiently lit work area.

Do not allow unauthorized persons, especially children and animals, to touch the tools or electrical cables, and keep them away from the work area.

Turn off the machine when you have finished using it. Always disconnect the power supply.

Never leave the machine unattended while it is running. Only leave the machine when it has come to a complete stop.



Do not force the band; it will perform better and be safer at the speed for which it is designed.

Do not use bands for tasks for which they are not intended.



Do not damage the power cord.

Never pull on the power cord to remove it from the electrical outlet.

Keep the power cord away from heat sources, greasy areas, and/or sharp edges.

Protect the power cord from moisture and any potential damage. Check the power cord periodically. If damaged, have it repaired by an authorized repairer.

Defective switches must be replaced by a qualified person or an authorized repairer.

Do not use the machine if the switch does not control the stop or start functions.



Do not overestimate your strength.

Always maintain a stable position and good balance.

Pay attention to what you are doing and use common sense.

Do not use the machine when tired.

Always use both hands to operate this machine.

The use of any accessories other than those described in the instruction manual may present a risk of injury to persons.

The user is responsible for their machine and must ensure that:

The machine is used by persons who have read the instructions and are authorized to do so.

Safety rules are followed.

Users have been informed of the safety rules.

Users have read and understood the instruction manual.

Responsibilities for maintenance and any repairs have been assigned and observed.

Defects or malfunctions have been immediately reported to an authorized repairer or your dealer.

The machine must be used in the areas of application described in this manual.

Any use other than that specified in this instruction manual may constitute a hazard.

Mechanical and/or electrical guards must not be removed or bypassed.

No modifications and/or conversions must be made.

PEUGEOT OUTILS PROFESSIONNELS declines all responsibility for damage caused to persons, animals, or objects as a result of failure to comply with the instructions and safety rules contained in this instruction manual.

### 3.2 SPECIAL SAFETY REQUIREMENTS



#### Special safety requirements for the band saw.

Before use, the machine must be correctly assembled.  
 Do not use if the machine is not placed on a flat, stable surface that is free of obstacles and well lit.  
 Do not operate the machine when the safety guards are removed.  
 Do not use a welding machine or any other device that could overload the same electrical circuit as the machine.  
 Fit a band that complies with the machine's recommendations.  
 Only use bands recommended by PEUGEOT OUTILS PROFESSIONNELS.  
 Ensure that the choice of band and teeth correspond to the material and cross-section of the part to be cut.  
 Use appropriate cutting speeds.  
 Ensure that the band is correctly mounted.  
 Check that the band is correctly tensioned.  
 Do not use damaged or deformed bands.  
 Do not use this machine to cut building materials (concrete, cinder blocks, paving stones, stone, etc.), wood, PVC, or derivatives.  
 Machine non-ferrous metals (stainless steel, aluminum, copper, lead, zinc, tin, brass, etc.) at an appropriate speed using the speed control (minimum speed for stainless steel, maximum speed for aluminum, for example), with a gradual and correct descent, and with an appropriate band.  
 Do not stop the band by hand.  
 Do not touch the moving band.  
 Always keep the band clean.  
 Do not clean the band while it is moving.  
 The band can become very hot during machine operation. Wait for the band to cool before replacing it.  
 Always keep the band saw frame clean and uncluttered.  
 Do not add additional accessories for operations for which they are not designed.  
 Using an inappropriate accessory can lead to accidents.  
 Keep hands away from cutting areas when the machine is in operation.  
 Never hold the workpieces by hand; clamp them securely in the vise.  
 Do not start cutting with the blade against the workpiece.  
 Do not hit the band against the workpiece, but apply pressure gradually.  
 It is very important to prevent cutting fluid from spilling onto the surrounding area, as this creates a slipping hazard.  
 Always work in a stable position and maintain your balance.  
 Always wear protective eyewear.  
 Ensure that no one is in the path of debris and sparks caused by cutting.  
 Always keep the work area clean and uncluttered.  
 In all cases, stay focused on the task at hand.

For all operations involving a risk of cutting, burning, pinching, snagging, entanglement, or crushing, in particular when loading and unloading parts to be cut, changing the band, or handling the part to be cut and the vise, stop the machine and wear protective gloves.  
 Rushing rarely saves time: the band heats up, becomes dull, and needs to be resharpened. The work is poorly done. The risk of accidents is increased.

Wear hearing protection.

If necessary, wear respiratory protection to reduce the risk of inhaling hazardous dust.

Keep the fan cover clean and uncovered to ensure the machine operates correctly.

Before changing a cutting part or blade, and before performing any operation to position or remove waste material, stop the machine.

Disconnect the power supply for any major operations (maintenance, servicing, etc.).

Replace the vise base when it is worn.

Keep the machine clean and in good condition.

Remove chips regularly.

When cleaning, remove any chips that may be sharp and hot while wearing protective goggles and gloves, with the machine switched off, and collect them in bins. Avoid using an air gun; instead, use a clean, dry cloth, a brush, a long-handled brush, a hook, a magnetic collector, or a vacuum cleaner.

Do not immerse the machine in water or wash it with a pressure washer, as this may cause water to penetrate the electrical components.

Do not use solvents or aggressive detergents for cleaning.

When the machine is not in use for a prolonged period, place the bow in the rest position ("LOW" position).

Disconnect the machine and check that the moving parts are locked when transporting the band saw.

Store the machine in a dry place out of the reach of children.



Accidents are generally the result of:

- Lack of accessories to hold the part securely in place.
- Disorder: accessories, if they exist, are not stored properly and the operator cannot find them, so does without them.
- Inappropriate or dangerous operating procedures.
- Insufficient training, learning, and/or experience of operators in the use of the machine.
- Absence of protective covers during machine use.
- Ill-fitting clothing, lack of safety glasses for certain tasks.

### 3.3 OPERATOR PROTECTION



#### For operator safety, ensure that non-working parts are always covered by a protective guard.

This machine is designed for a single operator.  
 The operator must wear appropriate personal protective equipment:

- During use:
  - Safety shoes.
  - Safety glasses.
  - Hearing protection.
  - Protective gloves.
  - Respiratory protection.
- When cleaning the machine or changing the band:
  - Safety shoes.
  - Safety glasses.
  - Protective gloves.



The operator must wear close-fitting clothing and, if necessary, hair coverings for long hair.

The operator must not wear, for example:

- Loose-fitting clothing with wide sleeves.
- Bracelets, watches, wedding rings, jewelry, ties, scarves.
- Any other objects that could get caught in the moving parts of the machine.



## 4 DESCRIPTION AND OPERATION

### 4.1 INTENDED USE OF THE MACHINE

The PSR200AVE band saw is a machine designed and manufactured solely for making, in regular use (3-5 hours/day), cuts in ferrous metals (steel, iron, cast iron) and non-ferrous metals (stainless steel, aluminum, copper, lead, zinc, tin, brass, etc.), profiles or solids, using a suitable endless rotating band with lubrication.

The manufacturer declines all responsibility in the event of misuse or cutting of materials other than those mentioned above. Under proper conditions of use and maintenance, safe operation and performance are guaranteed for several years. To do this, explore the machine's various functions.



**Do not use this machine to cut construction materials (concrete, cinder blocks, paving stones, stone, etc.), wood, PVC, or derivatives.**

**Machine non-ferrous metals (stainless steel, aluminum, copper, lead, zinc, tin, brass, etc.) at an appropriate speed using the speed variator (minimum speed for stainless steel, maximum speed for aluminum, for example), with a gradual and correct descent, and with a suitable band.**

### 4.2 FEATURES

- Band speed variator.
- Steel cast iron bow.
- Band guides equipped with bearings ensuring excellent resistance to belt wear.
- Adjustable mobile front band guide.
- Autonomous gravity descent controlled by hydraulic cylinder.
- Two-point lubrication system with electric pump.
- Manual adjustment of band tension.
- Band tension gauge equipped with an electric safety lock.
- Quick-release clamp mounted on a slide with play compensation.
- Control panel on front panel.
- Very low voltage 24 V controls.
- Latching punch stop.
- Band housing equipped with an electric safety lock.
- Motor protection by thermal circuit breaker.
- IP 54 electrical insulation.
- Motor with coaxial gearbox.
- Supplied as standard with:
  - base;
  - Band (6/10 teeth);
  - 500 mm adjustable cutting stop

Capacities of cutting (mm)	Round	Square	Rectangular (L x W)	Opening Vise (mm)	Height Working working (mm)	Dimensions Band (mm)	Speeds Band (m/min)	Power	Power motor (kW)	Weight (kg)	Dimensions (L x H x W)
90	170	170	200 x 160	200	880	2080 x 20 x 0.9	20 ~ 90	230 V single-phase	1.5	155	1500 x 1600 x 1000
45° G	110	110	125 x 85								

### 4.3 ACCESSORIES (OPTIONAL)

	Length (in)	Width (mm)	Number of rollers	Diameter rollers (mm)	Height min/max (mm)	Maximum load * (kg)	Weight (kg)	Reference
Rolling stock	1000	430	4	60	800 / 1000	700	27	PPM00500001
Rolling stock	200	430	7	60	800 / 1000	1400	47	PPM00500002
Rolling feed extension	200	430	7	60	800 / 1000	1400	40	PPM00500003
Rulers with stop	100	-	-	-	-	-	-	PPM00500004
	2000							PPM00500005
	3000							PPM00500006
	4000							PPM00500007

### 4.4 CONSUMABLES (OPTIONAL)

To achieve an excellent cut finish and ensure the band lasts as long as possible, it is essential to choose the right band teeth, and to adjust the bow drop speed and band speed according to the profile of the part to be cut. Use original PEUGEOT OUTILS PROFESSIONNELS bands.

Available range:

	Teeth 8/12	Teeth 6/10
Reference	PPA403420800812	PPA403420800610



## 4.5 MACHINE DESCRIPTION



- |     |  |     |                         |
|-----|--|-----|-------------------------|
| 1.  | Bow arm                                    | 16. | Control panel           |
| 2.  | Band tension gauge                         | 17. | Base                    |
| 3.  | Tape tension microswitch                   | 18. | Bow clamping lever      |
| 4.  | Band tension adjustment wheel              | 19. | Frame                   |
| 5.  | Movable band housing                       | 20. | Bow holder              |
| 6.  | Movable front tape guide adjustment handle | 21. | Adjustable cutting stop |
| 7.  | Movable front band guide clamp             | 22. | Cutting fluid pump      |
| 8.  | Movable front band guide                   | 23. | Hydraulic cylinder      |
| 9.  | Movable front band guide guard             | 24. | Bow spring              |
| 10. | Quick-release clamp lever                  | 25. | Fixed rear band guide   |
| 11. | Fixed rear vise jaw                        | 26. | Cutting fluid valve     |
| 12. | Movable front vise jaw                     | 27. | Cutting fluid hose      |
| 13. | Vise base                                  | 28. | Gear motor              |
| 14. | Bow graduation                             | 29. | Bow                     |
| 15. | Vise handwheel                             |     |                         |

## 5 INSTALLATION

### 5.1 PACKAGING



**A small moisture-proof bag may be included in the packaging. Keep out of reach of children and dispose of it.**

The band saw is packaged in a palletized cardboard box, secured with a tie-down device, for easy handling, transport, and storage. Use a pallet truck or forklift to move the band saw. Several people are required to set it up. When unpacking, remove each part of the machine, check its overall condition, and then proceed with assembly.

Check that the machine is clean. The machine is delivered with the ground parts coated with a protective anti-rust oil. If the product does not appear to be in good condition or if any parts are broken or missing, contact your dealer. Keep the instruction manual for future reference.

### 5.2 HANDLING AND TRANSPORT



Given the weight (155 kg) and dimensions of the machine, handling and installation must be carried out using appropriate means and with the assistance of several people.

To lift the band saw, use a slinging system (e.g., polyester cables of adequate capacity with the rings provided) and position it in the holes located on either side at the front and rear of the frame, provided for this purpose (see attached figure).

Check that the moving parts are locked and lift the band saw with the utmost care; keep people who are not involved in the lifting away.

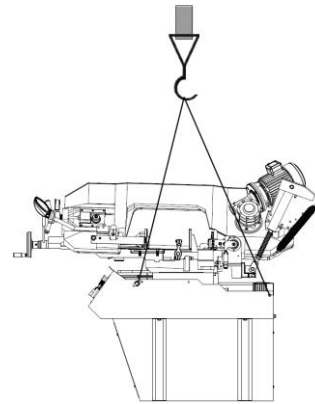

### 5.3 INSTALLATION OF THE MACHINE



#### Installation environment

- Power supply voltage in accordance with the machine's specifications
- Ambient temperature between +5°C and +35°C
- Relative humidity not exceeding 90%
- Sufficient ventilation at the installation site
- Work area sufficiently lit for safe working: lighting must be 500 LUX

Consider the location of the machine in the room; it must allow for easy movement and maneuvering. Maintain a minimum distance of 800 mm between the rear of the machine and the wall. Before installation, fully assemble the base by joining the 4 panels and check all fastenings (see section 5.4). Position the base on a sufficiently flat, non-slip surface so that it is as stable as possible.

Then carefully position the band saw on the base. Secure the machine to the base using the fixing bolts and nuts. Place the machine on a concrete floor approximately 200 mm thick and 100 mm wider than the frame on each side. Ensure that the floor surface is level and smooth. Secure the machine to the floor using the appropriate screws (M12) driven into the concrete so that it is as stable as possible. Before tightening the screws, check that the band saw is level. Check that the surfaces of the band saw are free of dust and chips and, if necessary, coat the bare parts with a protective oil film.

### 5.4 ASSEMBLY

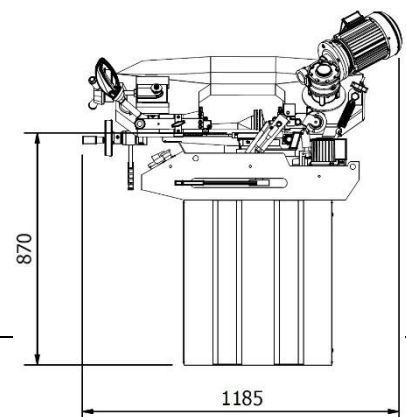
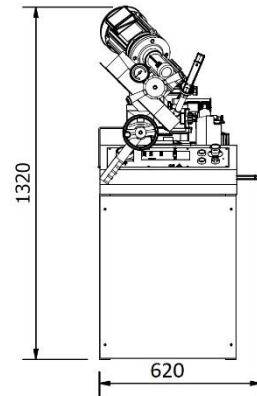

**A. Base**

- Assemble the four base panels using the fixing screws.

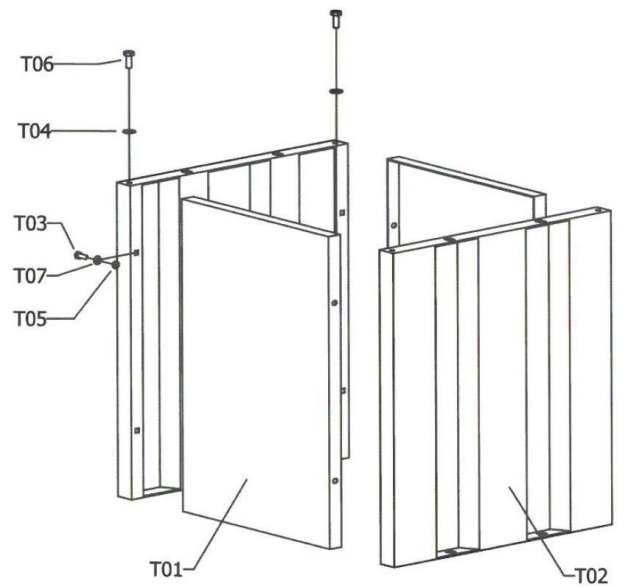

**B. Cutting stop**

- Screw the cutting stop pin (A) into its seat on the right-hand side of the vice (B), then lock it in place.



**C. Liquid cutting plate**

- Position and secure the liquid cutting plate (101) correctly on the rear left side of the frame (2) using the appropriate screw.

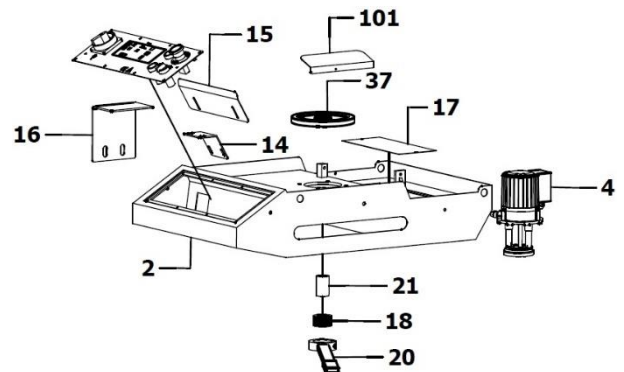

**D. Front cutting fluid plate**

- Position and secure the front plate (15) correctly on the front of the frame (2) using the appropriate knobs.

## 5.5 ELECTRICAL CONNECTION



**Electrical work must be carried out by qualified personnel authorized to perform low-voltage electrical work.**



**Electrical supply**

Ensure that the supply voltage of the electrical installation corresponds to that of the machine.

Connect using the machine's power supply cable.

Check that the electrical outlet of the installation is compatible with the machine's plug (2P+T).

The socket used for connection must comply with the "EN 60309-1" standards.

Check that the electrical installation to which the machine will be connected is properly earthed in accordance with current safety standards.

Do not use a welding machine or any other device that could overload the same electrical installation line as the machine.

We remind the user that there must always be a magnetothermal protection device upstream of the electrical

installation to protect all conductors against short circuits and overloads.

This protection must always be selected based on the electrical characteristics of the machine, as specified on the nameplate:

- Voltage: 230 V single-phase
- Frequency: 50 Hz
- Motor power: 1.5 kW
- Current: 6 A
- Protection rating: IP 54



At the end of the machine's power cable is an electrical plug approved (NF EN 60309-1) in accordance with current regulations. The yellow-green protective conductor is on the corresponding terminal marked (earth logo).



**Do not use a welding machine or any other device that could overload the same electrical installation line as the machine.**



**Use of the machine with a damaged power cable is strictly prohibited. Regularly check the condition of the power cable, switches, and cable gland.**



**Use a cable reel with a cross-section and length appropriate for the power of the machine, and unroll it completely. Electrical connections and extension cords must be protected from splashes and kept on dry surfaces.**



**Do not remove the plug from the electrical outlet by pulling on the cord; pull only on the plug.**



**Check the direction of band feed (there is a pictogram on the machine) and the direction of rotation of the electric pump. The warranty does not cover damage caused by incorrect connection.**

## 5.6 INITIAL TESTING AND INSPECTION BEFORE FIRST USE

- Check that the band saw is securely attached to its frame, that the frame is attached to the base, and that the base is positioned and secured on a sufficiently flat and non-slip surface so that it is as stable as possible.
- Check that the moving parts are working properly and that there are no damaged components.
- Check that the guards are present, intact, and in good working order.
- Check the condition of the band.
- Check the up/down movement of the bow, the band casing, and the rotation of the bow.
- Check that the machine runs perfectly when empty.

## 6 BAND



**Never install damaged ribbon.**  
**Check that the band is clean.**  
**Install a belt that complies with the machine's recommendations for use.**



**Replace the band when the teeth are worn or broken to avoid additional vibrations and inaccurate cuts.**



**The band can become very hot during machine operation. Wait for the band to cool before replacing it.**



**Only use PEUGEOT OUTILS PROFESSIONNELS bands that comply with the original specifications: 2080 x 20 x 0.9 mm.**  
**Always use 0.9 mm thick bands.**



**Gloves and safety glasses must be worn.**

## 6.1 RECOMMENDED BAND

**A. Material classification**

Various parameters such as material hardness, the shape and thickness of the part to be cut, the choice of tape, the cutting speed, and the bow descent speed must be taken into account to achieve optimum cutting quality. Various problems can be solved more easily if the operator is familiar with these specifications.

**B. Choice of band**

Bands differ mainly in their construction characteristics, such as the shape and angle of the teeth, the tooth pattern, and the set. In order to optimize cuts, adapt the tooth configuration of the band to the thickness of the profile:

1. Determine the dimensions of the band.
2. Determine the appropriate tooth configuration\*:
  - Use the tables opposite.
  - Select the size and shape of the workpiece to be cut.
  - Find the corresponding teeth.
  - As a general rule, when choosing between two tooth sizes, the finer tooth size will result in a longer band life.
  - For cutting multiple pieces of the same shape and size into bundles, determine the tooth count for a single piece and then choose a higher pitch\*.

Tooth pitch: number of teeth per inch (1 inch = 25.4 mm) (recommended value, check with the band manufacturer).

✓ 2080 x 20 x 0.9 mm band.

Recommendations for the blade:

- For cutting solid bars, 6/10 teeth.
- For pipes, thick profiles, and solid bars with a diameter < 50 mm, use 8/12 teeth.
- For thin pipes and profiles, use 10/14 teeth.

Tubes and profiles	Profile thickness (E) (mm)	Tooth pitch (mm)
	1 to 2	14/18
	2 to 3	10/14
	3 to 4	8/12
	4 to 5	6/10
	5 to 7	5/8
	7 to 15	4/6
	15 to 25	3/4
	30 to 50	2/3

Solid materials	Solid section (S) (mm)	Tooth pitch (mm)
	5 to 10	14/18
	10 to 15	10/14
	15 to 20	8/12
	20 to 25	6/10
	25 to 50	5/8
	50 to 75	4/6
	75 to 100	3/4
	150 to 200	2/3

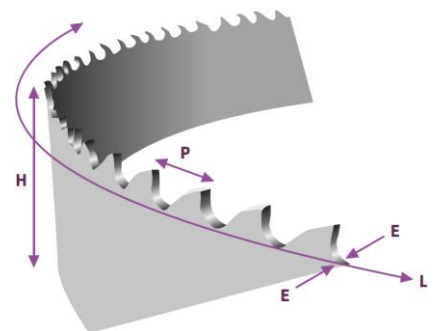

E: thickness of the blade back  
 H: height of the band measured between the back and the tip of the tooth  
 L: length of the band (total circumference)

### C. Cutting speed and feed rate

The cutting speed (m/min) and feed rate (cm<sup>2</sup>/min = distance traveled by the teeth during chip removal) are limited by the heat generated near the tooth tips:

- The cutting speed depends on the strength of the material ( $R = N/mm^2$ ), its hardness (HRC), and the dimensions of the highest section.
- An excessively high feed rate (or bowing) tends to cause the band to deviate from the ideal cutting path, producing non-straight cuts both vertically and horizontally.



Recommendations for cutting speeds:

- 20 m/min for steel alloys, strength from 80 to 130 kg/mm<sup>2</sup>.
- 65 m/min for carbon steels and alloys, strength up to 80 kg/mm<sup>2</sup>.

### D. Tips for using the blade

- When mounting the band, it is essential to ensure that the teeth are facing in the correct direction. When positioning it on the guides, care must be taken to ensure that the back of the band does not come into contact with the guide collars and that it is stretched out straight. The lateral sides of the band must be guided constantly and without pressure.
- Before starting the machine, ensure that the band tension is adjusted according to the machine's instruction manual. The tension is determined by the width of the band. If the band tension is insufficient, it will cut at an angle; if the tension is too high, the band will break and the machine will suffer premature wear.
- Each time a new band is installed, perform a break-in period:
  1. Reduce the band speed by approximately 20% and the bow descent speed by 25%.
  2. Run in the ribbon during the first few cuts in a solid section, with the running-in time corresponding to a total cutting area of approximately 300 cm<sup>2</sup>.
  3. Once the running-in process is complete, increase the band speed and then the bow descent speed to the recommended values.
- The cut is more precise if the Band guides are close to the workpiece.
- To ensure perfect chip removal, the brush must be positioned correctly.
- Lubrication is essential for most metals. For aluminum and its alloys, it helps to remove chips from the teeth in order to obtain a better cut surface finish. Cast iron, brass, and other non-metallic materials (plastic, graphite, etc.) do not require lubricant.
- The shape of the chips provides information about the cutting pressure and cutting conditions:



Moderate coiling; correct cutting conditions



Very tight coiling or with bluish tones: feed rate too high



Very fine or powdery chips: insufficient feed

## 6.2 ASSEMBLY/DISASSEMBLY OF THE BAND

### A. Principle

1. Raise the bow (29 fig.1) and lock it in place using the jack (23 fig.1).
2. Remove the front movable band guide guard (9 fig.1).
3. Remove the removable band cover (5 fig.1) by unscrewing the appropriate screws.



4. Loosen the band by turning the band tension adjustment wheel (4 fig.1) to the left, taking care (risk of the band springing back).
5. Carefully remove the defective band from the pulleys.
6. Clean the band guides and pulleys (using a clean cloth) to remove any accumulated shavings (the main cause of misaligned cuts).
7. Insert the new band, paying attention to the position of the teeth, first positioning it in the band guides and then on the pulleys.
8. Check that the back of the tape (non-cutting part) rests firmly at the bottom of the tape guides.
9. Apply slight tension to the band by turning the band tension adjustment wheel (4 fig.1) to the right, ensuring that the band is perfectly positioned on the pulleys.
10. Refit the removable band cover (5 fig.1).
11. Refit the front movable band guide guard (9 fig.1).
12. Tension the band so that the spring washers behind the pressure gauge are fully compressed. This will ensure that the band is correctly tensioned (the ideal band tension is 1000 kg/cm<sup>2</sup>, in the green zone of the pressure gauge). Make sure that the band tension safety device is engaged.
13. Run the machine empty for 5 minutes to check that the band is correctly positioned on the pulleys and in the guides.
14. Tighten the band, if necessary.



**Loosen the band at the end of the day.**



**In order to obtain an excellent cut finish and long band life, it is essential to choose the correct belt teeth, and to adjust the bow drop speed and motor speed according to the profile of the workpiece to be cut.**



**Do not use bands with dimensions other than those specified.**



**Ensure that the teeth of the band are correctly oriented during installation.  
If the teeth of the band are reversed, twist the band so that it changes direction.**

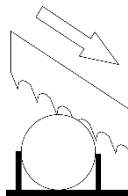

**B. Position of the band on the pulleys**

The band must be correctly guided on the pulleys before each use to enable the band to make a straight cut.

During operation, the band must be positioned at the correct distance from the pulleys, between 0.5 and 2 mm.

Always use bands with the appropriate teeth.

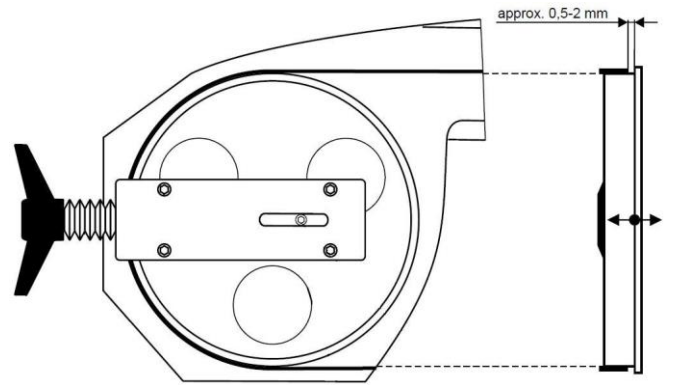

**C. Position of the band in the band guides**

The band (A) (0.9 mm thick) is guided by two band guides (B) that are installed during adjustment before the band saw is operated. During operation, the band must maintain a correct distance of between 0.5 and 1 mm from the band guides.

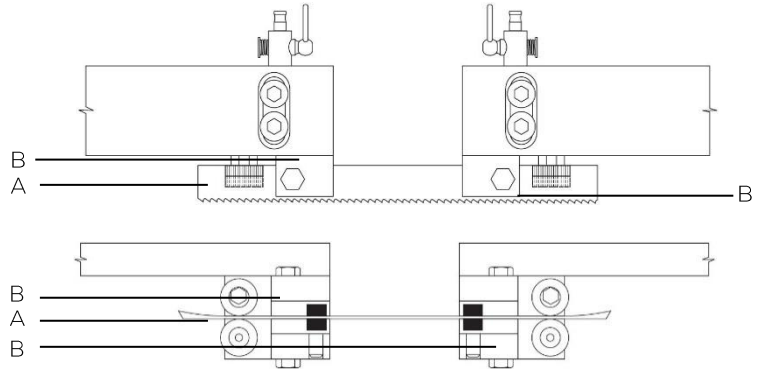

The adjustment of the bearings and band guides mainly affects the blade's service life and the quality of the cut.

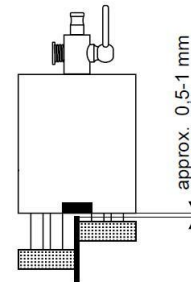

Do not position the band as shown in the accompanying figures:

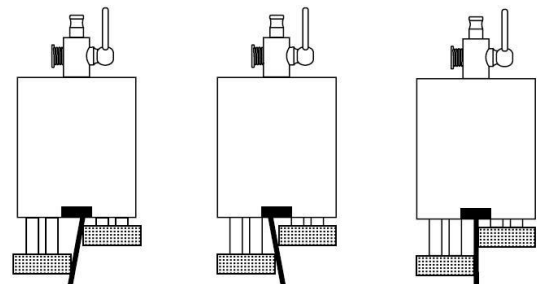

## 7 USE



Follow the specific safety instructions for the band saw (section 3.2).



Before starting operation, familiarize yourself with the controls.



Wearing appropriate personal protective equipment is mandatory.



Before performing any maintenance or servicing, disconnect the machine.

 7.1  CONTROL DEVICES

## A. Control panel



## A. MACHINE OPERATION BUTTON:

- Pressing the green "I" button activates the machine's band. The button indicator light comes on.



During operation, the bow must be raised so that it does not come into contact with the end-of-cut sensor. Otherwise, the machine will not operate.

## B. STOP BUTTON:

- Pressing the red "0" button stops the band and the cutting fluid pump.



Pressing the button causes the bow to continue descending if the knob or lever on the hydraulic cylinder is not set to "0".

## C. STOP PUNCHING WITH LOCKING:

- General shutdown of the machine.



Pressing the lock-in punch stop causes the bow to continue descending if the knob or lever on the hydraulic cylinder is not set to "0".

## D. CUTTING LIQUID SWITCH:

- Position "0": the cutting fluid pump is inactive.
- Position "1": the cutting fluid pump is activated (when the green "I" button is pressed).

## E. BAND SPEED POTENTIOMETER:

- The band speed can be adjusted using the potentiometer (from 20 m/min to 90 m/min):
  - 0 m/min: blade stopped
  - 20 m/min: low speed suitable for solid or hard materials
  - 90 m/min: high speed suitable for thin-walled profiles and tubes

## B. Hydraulic cylinder

Thanks to the hydraulic cylinder, the descent of the bow is continuously adjustable in order to adapt the cutting conditions to the shape of the piece to be cut (thin profiles, solid profiles, etc.) and the nature of the piece:

## H. ARCH DESCENT SPEED DIAL:

- Allows you to vary the speed of the bow's descent.

## I. BOW DESCENT LEVER:

- Allows the bow descent to be locked in the "horizontal" position.
- Allows the bow to be immobilized in an intermediate position without having to return to the upper position.
- Allows the bow to descend to the "vertical" position.

## J. CUTTING END MICROSWITCH:

- At the end of the cut, the band and the cutting fluid pump stop.

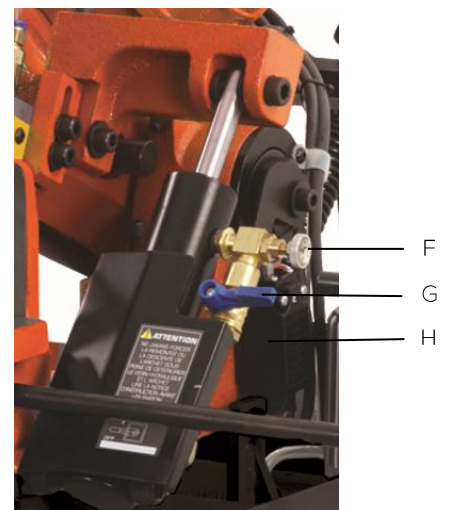

Never force the bow up or down, as this may damage the hydraulic cylinder and the bow.

## 7.2 ADJUSTMENTS



**Disconnect the machine's power supply before performing these operations.**

### A. Angle cuts

The band saw can be used to make cuts at 0°, 45° left, and intermediate angles:

1. Set the bow to the "HIGH" position.
2. Loosen the bow clamping lever (A) to the left.
3. Turn the bow support (B) using the bow arm and set it to the desired angle using the scale (the angle stops are located at 0° and 45° left).
4. Tighten the bow clamp lever (A) to the right.



**Firmly lock the bow clamping lever to prevent the bow from changing position during cutting.**

### B. Vise assembly

The clamp is equipped with a quick-release lever (A) with a movable front jaw displacement of approximately 5 mm:

1. Place the workpiece against the fixed rear vise jaw (B).
2. Using the vise wheel (D), move the front movable vise jaw (C) approximately 2 mm toward the workpiece to be cut.
3. Tighten the workpiece using the quick-release vise lever (A) to the left before cutting.
4. Ensure that the workpiece is securely clamped in the vise to prevent it from moving during cutting.
5. For a second cut in the same workpiece, loosen only with the quick-release vise lever (A) to the right.



Vise opening: 200 mm maximum.

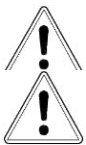

**Before making a cut, ensure that the workpiece is securely clamped in the vise to prevent it from shifting during the cut.**

**Do not place workpieces to be cut on the vise assembly:**

- During cutting.
- When a workpiece is already inserted in the vise.

### Adjusting the vise wedge:

There may be some lateral play in the vise. The wedge that holds the vise to its support is misaligned. This lateral play can be adjusted using the screws (A) on the left side of the vise:

1. Open the clamp as wide as possible.
2. Loosen the adjustment screws (A) on the vise set.
3. Carefully tighten the first adjustment screw on the vise set (to the right of the movable front jaw) until you feel the screw (through a support ball) resting on the bar that pushes into the groove.
4. In this position, tighten the screw.
5. Use the vise wheel to move the vise so that the next vise adjustment screw is in the same position as the previous screw.
6. Repeat steps 3, 4, and 5 until the vise is completely closed and therefore adjusted.

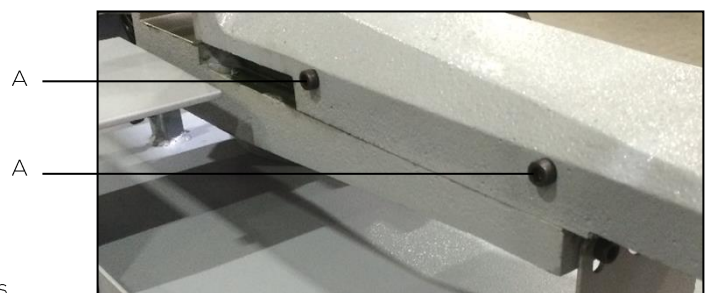

### C. Tensioning the band

Before starting the machine, the band must be sufficiently tensioned to ensure proper cutting conditions:

- Turn the band tension adjustment wheel (A).
- Ensure that the band tension microswitch (B) is engaged.
- The ideal band tension is 1000 kgs/cm<sup>2</sup>, in the green zone of the pressure gauge (C).



Loosen the band at the end of the day.



**If the band tension is insufficient or if the band breaks, the machine will not start due to the band tension microswitch.**



**Use original tapes to ensure correct band tension.**

### D. Movable front band guide

To achieve an optimal cut and work safely, adjust the movable front band guard (A) as close as possible to the workpiece!

1. Loosen the clamping handle (B) on the movable front band guard (A).
2. Slide the movable front band guard (A) as close as possible to the workpiece using the adjustment knob (C), so as not to interfere with the end of the cut (there is a stop (D) on the guide).
3. Tighten the clamping handle (B) on the movable front blade guide (A).



**Perform this adjustment each time the workpiece dimensions change.**



**Make sure to adjust the movable front band guide so that it does not touch the bottom of the vise at the end of the cut.**

### E. Bow balancing spring

The bow is balanced using a tension spring (A). Avoid changing the original/factory setting of the spring. Otherwise, too much tension would prevent the bow from descending freely.

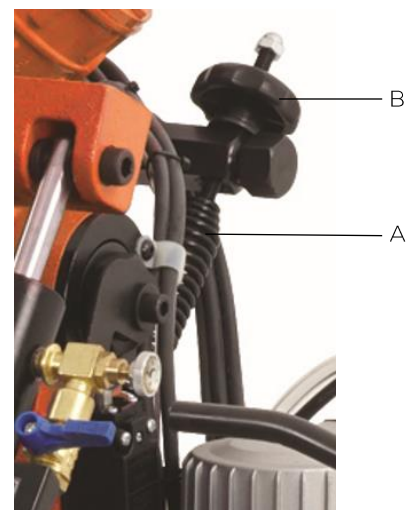

## F. Cutting stop

The length of the piece to be cut can be adjusted using the cutting stop (A):

1. Screw the cutting stop pin (B) into its seat on the right base of the vice (C), then lock it in place.
2. Slide the cutting stop support (D) onto the pin (B) to the desired cutting length, then tighten the support (D) using the adjustment screw (E).
3. Adjust the stop (A) if necessary.
4. Place the workpiece to be cut in the vise so that its end touches the stop (A).
5. Clamp the workpiece in the vise.
6. Check the length of the workpiece.

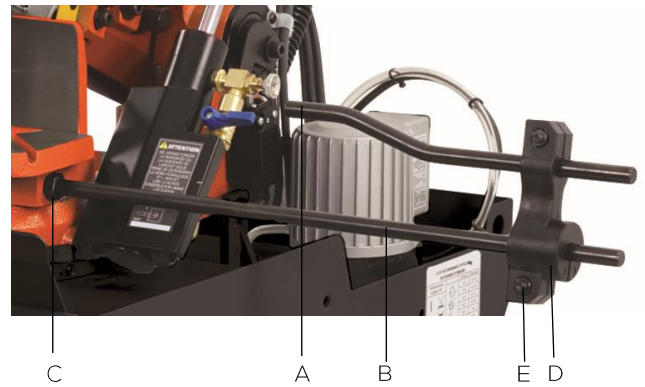

## G. Bow stroke

The bow downstroke can be adjusted using the depth stop (A) located below the bow (the stop is factory-set):

1. Place the bow in the "LOW" position.
2. Loosen the locknut (B).
3. Tighten or loosen the stop screw (A) as needed.
4. Then retighten the lock nut (B).

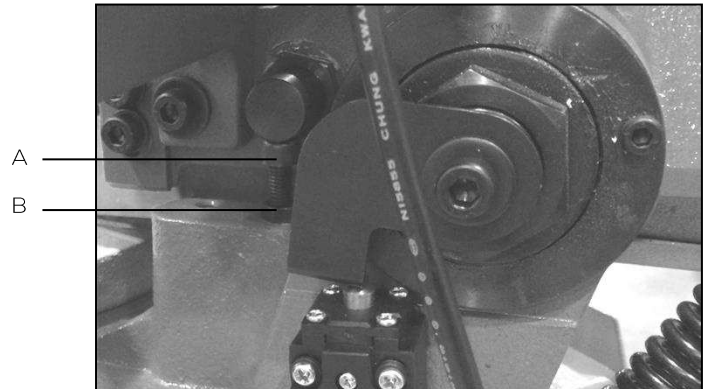

**The stop screw must not be tightened too far, as this will cause the band to cut into the vise base.**

**Ensure that the stop screw is always at the correct height before starting the machine.**

## H. Archery return stroke

The bow return stroke can be adjusted using the bow height stop (A) located underneath the bow (the stop is factory-set):

1. Loosen the stop screw (A).
2. Tighten or loosen the lock nut (B) as needed.
3. Adjust the maximum cutting height of the bow (leave a margin of approximately 5 to 10 mm between the band and the piece to be cut).
4. Then retighten the stop screw (A).
5. Check the height using the workpiece inserted in the vise.
6. At the end of the cut, manually raise the bow to the set height.

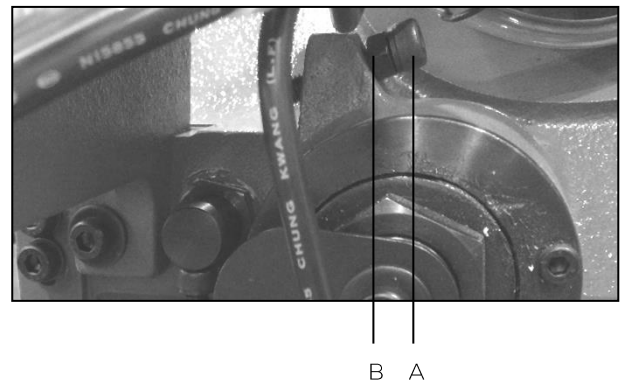

## 7.3 CUTTING FLUID



**Disconnect the machine from the power supply before performing this operation.**  
**For cleaning, remove any chips that may be sharp and hot, wearing protective goggles and gloves, and collect them in containers.**  
**Avoid using an air gun; instead, use a clean, dry cloth, brush, long-handled brush, hook, magnetic collector, or vacuum cleaner. Do not use solvents or aggressive detergents.**



**It is very important to prevent cutting fluid from spilling onto the surrounding area, as this creates a slipping hazard.**

The band saw has a two-point lubrication system powered by an electric pump:

- Ensure that a sufficient quantity of cutting fluid (composed of water and soluble oil) is poured into the filling tank located in the frame at the rear of the machine (19 fig.1) (remove the grid beforehand).
- The capacity of the filling tank is approximately 5 liters.
- Dilute the soluble oil according to the percentages specified by the product manufacturer (generally 10% to 15%).
- Spraying is provided by a cutting fluid pump (22 fig.1) that draws the cutting fluid from the filling tank.
- Set the cutting fluid pump switch to the "I" position on the control panel.
- The cutting fluid pump is activated when the green "I" button on the control panel is pressed.
- Adjust the flow rate using the taps (A) located on either side of the band guides (B).
- Ensure that there is sufficient cutting fluid to lubricate the band generously.
- Lubrication is essential for most metals. It helps to remove chips from the band, resulting in a better cut surface finish.

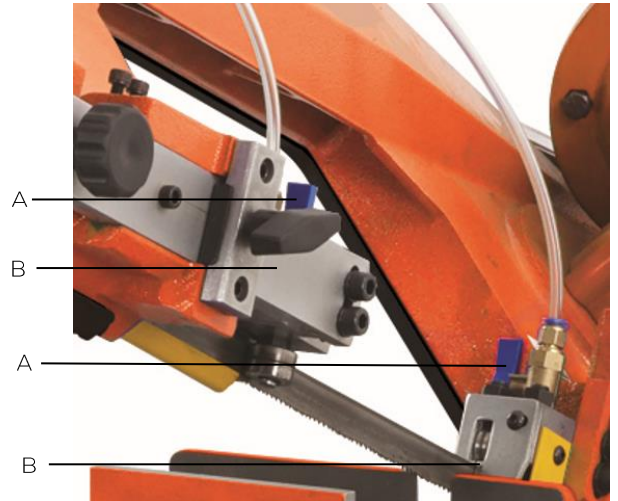
**Cleaning the lubrication system:**

1. Drain the cutting fluid using the drain screw (C) located at the rear of the machine.
2. Remove the grille (D) located on the frame at the rear of the machine and clean it.
3. Remove the cutting fluid pump, clean it and the hoses.
4. Clean the filling tank.
5. Replace the drain screw (C).
6. Fill the filling tank (approx. 5 liters).
7. Replace the pump and the grille (D).

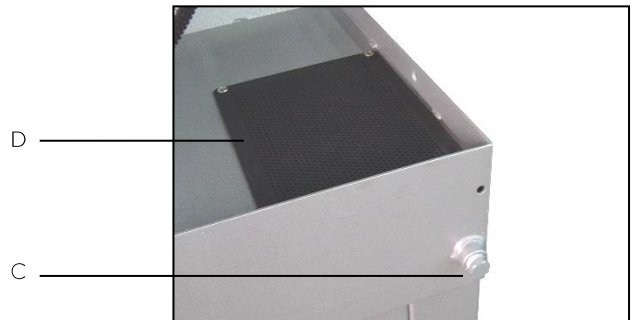
**Electrical specifications of the pump:**

- Power: 0.1 kW
- Voltage: 230 V
- Frequency: 50 Hz
- Current: 0.3 A

## 7.4 POSITION OF PARTS IN THE VISE



**Never hold the parts to be cut by hand.**

To ensure precise cuts, optimum performance, and increased band life, the figures below show recommendations for clamping parts in the vise according to their shape (for straight cuts at 0°). The parts to be cut must be placed directly between the jaws without any other objects in between.

Always ensure that the workpiece is perpendicular to the blade and that the guides are as close as possible to the workpiece. The band guides must not exert any pressure on the band. Obviously, the band teeth must protrude sufficiently from the guides. An incorrectly mounted and clamped workpiece will cause damage to the teeth.

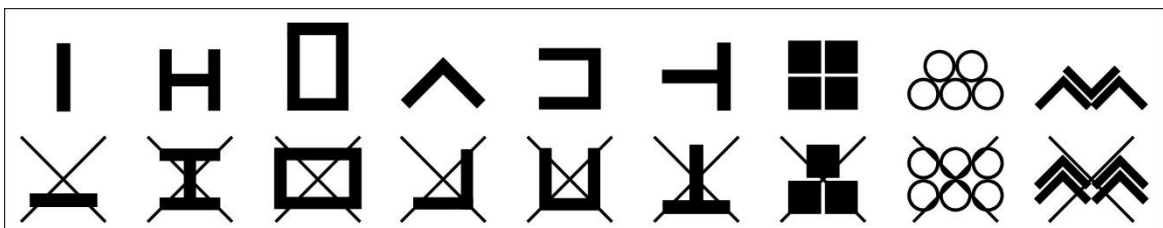

7.5  CUTTING PROCEDURE

**Wearing appropriate personal protective equipment is mandatory.**



**All operations relating to the cutting procedure must be carried out when the machine's bow is in the rest position and the band is stopped.**



**Keep hands away from the cutting areas when the machine is in operation.  
Stop the machine before positioning the part or removing cutting waste.**



**Always use the vise: the parts to be cut must be securely clamped in the vise to prevent any projections.**



**During use, there is a risk of sparks or hot metal debris being projected.**



**Do not apply excessive pressure to the band. Applying high pressure to the band does not improve machining performance, but will reduce the service life of the band and the machine.**

### A. Cutting instructions

1. Set the bow descent speed dial to "0."
2. Close the bow descent lever completely.
3. Set the bow to the "HIGH" position.
4. Set the bow to the desired cutting angle (see section 7.2).
5. If necessary, adjust the depth stop correctly (see section 7.2).
6. Check that the band is correctly tensioned (see section 7.2).
7. Insert the workpiece into the vise at the desired length and check its positioning (see sections 7.2 and 7.4).
8. Clamp the workpiece in place using the vice.
9. Ensure that the workpiece to be cut is securely clamped in the vise to prevent it from moving during cutting.
10. Adjust the front movable blade guide (see section 7.2).
11. Connect the machine's power supply (see section 5.5).
12. Unlock the safety switch and/or reconnect the safety devices (microswitches).
13. Press the green "I" button (D fig.2) to start the band.
14. Activate the cutting fluid pump with the switch in the "I" position.
15. Adjust the cutting fluid flow rate using the taps located on the band guides (see section 7.3).
16. Adjust the band speed to suit the material to be cut using the potentiometer.
17. Adjust the speed at which the bow descends toward the workpiece using the bow descent speed knob located on the hydraulic cylinder.
18. Open the bow descent lock lever located on the hydraulic cylinder.
19. Ensure that no one is in the path of debris and sparks caused by cutting.
20. Do not hit the band against the workpiece to be cut, but apply gradual and correct pressure. Do not start cutting with the blade against the workpiece.
21. At the end of the cut, the band and the cutting fluid pump will stop thanks to an end-of-cut sensor.
22. Deactivate the cutting fluid pump by setting the switch to the "0" position.
23. Carefully raise the bow once the cut is complete.
24. Open the vise.
25. Remove the cut piece.

### B. Stop

- Set the band speed potentiometer to "0".
- Press the red "0" button to turn off the band and the cutting fluid pump.
- Press the lockable emergency stop button.



At the end of the day, loosen the band and place the bow in the rest position ("LOW" position).

## 7.6 OPERATING INCIDENTS

### A. Band jammed in the workpiece



**Protective gloves must be worn.**

1. Stop the machine by pressing the emergency stop button.
2. Carefully raise the bow.
3. Carefully open the clamp.
4. Carefully remove the workpiece.
5. Check the condition of the band and replace it if necessary.



**Replace the band if it is damaged (e.g., broken teeth).**

### B. Restarting a cycle following a punch stop with engagement

1. Unlock the emergency stop.
2. Carefully raise the bow.
3. Press the green "I" button to activate the band and cutting fluid pump.

### C. Power failure

1. Carefully lift the bow.
2. Press the green "I" button to start the band and the cutting fluid pump.



**The machine is equipped with a very low voltage electrical system (24 V TBT) with a voltage failure device (preventing accidental restarting).**

7.7  FAULT AND SOLUTION TABLE

FAULTS	SOLUTIONS
Premature wear:	<ul style="list-style-type: none"> <li><input checked="" type="radio"/> <input type="radio"/> <input type="radio"/> Reduce speed.</li> <li><input checked="" type="radio"/> <input type="radio"/> <input type="radio"/> Increase the pressure of the bow to keep the teeth in contact with the material.</li> <li><input checked="" type="radio"/> <input checked="" type="radio"/> <input type="radio"/> Use a lubricant suitable for the material being cut.</li> <li><input checked="" type="radio"/> <input type="radio"/> <input type="radio"/> Spray the cut excessively for mild, extra-mild, and non-ferrous steels.</li> <li><input checked="" type="radio"/> <input checked="" type="radio"/> <input type="radio"/> Check that the band is mounted in the correct direction.</li> </ul>
Band vibrations during cutting:	<ul style="list-style-type: none"> <li><input checked="" type="radio"/> <input type="radio"/> <input type="radio"/> Increase or decrease the speed of the band.</li> <li><input checked="" type="radio"/> <input type="radio"/> <input type="radio"/> Increase the pressure.</li> <li><input checked="" type="radio"/> <input type="radio"/> <input type="radio"/> Increase the band tension.</li> <li><input checked="" type="radio"/> <input checked="" type="radio"/> <input type="radio"/> Use a finer pitch.</li> <li><input checked="" type="radio"/> <input type="radio"/> <input type="radio"/> Hold the workpiece more firmly.</li> </ul>
Tooth breakage:	<ul style="list-style-type: none"> <li><input checked="" type="radio"/> <input checked="" type="radio"/> <input type="radio"/> Use a finer pitch (for thin materials) or increase the pitch in other cases.</li> <li><input checked="" type="radio"/> <input type="radio"/> <input type="radio"/> Reduce the pressure.</li> <li><input checked="" type="radio"/> <input type="radio"/> <input type="radio"/> Hold the workpiece more firmly.</li> <li><input checked="" type="radio"/> <input type="radio"/> <input type="radio"/> Reduce the feed rate.</li> </ul>
Insufficient surface finish:	<ul style="list-style-type: none"> <li><input checked="" type="radio"/> <input type="radio"/> <input type="radio"/> Increase the cutting speed.</li> <li><input checked="" type="radio"/> <input type="radio"/> <input type="radio"/> Reduce pressure.</li> <li><input checked="" type="radio"/> <input checked="" type="radio"/> <input type="radio"/> Use a finer pitch.</li> <li><input checked="" type="radio"/> <input type="radio"/> <input type="radio"/> Lubricate the cut.</li> </ul>
Convex or concave faces or band kickback:	<ul style="list-style-type: none"> <li><input checked="" type="radio"/> <input type="radio"/> <input type="radio"/> Reduce the feed rate.</li> <li><input checked="" type="radio"/> <input type="radio"/> <input type="radio"/> Increase the band tension.</li> <li><input checked="" type="radio"/> <input checked="" type="radio"/> <input type="radio"/> Use a larger band pitch.</li> <li><input checked="" type="radio"/> <input type="radio"/> <input type="radio"/> Adjust the movable band guide as close as possible to the workpiece.</li> <li><input checked="" type="radio"/> <input checked="" type="radio"/> <input checked="" type="radio"/> Adjust the play of the band guides as close as possible to the band.</li> <li><input checked="" type="radio"/> <input type="radio"/> <input type="radio"/> Reduce the pressure.</li> </ul>
Premature band breakage:	<ul style="list-style-type: none"> <li><input checked="" type="radio"/> <input type="radio"/> <input type="radio"/> Reduce the speed.</li> <li><input checked="" type="radio"/> <input type="radio"/> <input type="radio"/> Reduce the pressure.</li> <li><input checked="" type="radio"/> <input type="radio"/> <input type="radio"/> Decrease the band tension.</li> <li><input checked="" type="radio"/> <input checked="" type="radio"/> <input checked="" type="radio"/> Check the surface condition of the band pulleys.</li> <li><input checked="" type="radio"/> <input type="radio"/> <input type="radio"/> Adjust the movable band guide as close as possible to the workpiece.</li> <li><input checked="" type="radio"/> <input type="radio"/> <input type="radio"/> Lubricate the cut.</li> <li><input checked="" type="radio"/> <input checked="" type="radio"/> <input checked="" type="radio"/> Check the band welding parameters.</li> </ul>
Chip jamming in the tooth:	<ul style="list-style-type: none"> <li><input checked="" type="radio"/> <input type="radio"/> <input type="radio"/> Use a larger pitch.</li> <li><input checked="" type="radio"/> <input type="radio"/> <input type="radio"/> Reduce the bow descent.</li> <li><input checked="" type="radio"/> <input type="radio"/> <input type="radio"/> Increase the cutting speed.</li> <li><input checked="" type="radio"/> <input type="radio"/> <input type="radio"/> Lubricate the cut.</li> </ul>
Poor contact between the band and the guides:	<ul style="list-style-type: none"> <li><input checked="" type="radio"/> <input checked="" type="radio"/> <input checked="" type="radio"/> Check the alignment of the Band pulleys.</li> <li><input checked="" type="radio"/> <input checked="" type="radio"/> <input checked="" type="radio"/> Check the wear on the band guides and replace them if necessary.</li> </ul>
Insufficient sawing speed:	<ul style="list-style-type: none"> <li><input checked="" type="radio"/> <input type="radio"/> <input type="radio"/> Increase the cutting speed.</li> <li><input checked="" type="radio"/> <input checked="" type="radio"/> <input type="radio"/> Use a larger pitch.</li> <li><input checked="" type="radio"/> <input type="radio"/> <input type="radio"/> Increase the pressure.</li> <li><input checked="" type="radio"/> <input type="radio"/> <input type="radio"/> Lubricate the cut.</li> </ul>
Premature disappearance of the band path:	<ul style="list-style-type: none"> <li><input checked="" type="radio"/> <input checked="" type="radio"/> <input checked="" type="radio"/> Band too wide for the radius to be cut.</li> <li><input checked="" type="radio"/> <input type="radio"/> <input type="radio"/> Reduce the cutting speed.</li> <li><input checked="" type="radio"/> <input type="radio"/> <input type="radio"/> Lubricate the cut.</li> </ul>

## 8 MAINTENANCE



**Before performing any maintenance or servicing, disconnect the machine.**  
**Wear gloves and protective eyewear, and use a clean, dry cloth, brush, long-handled brush, hook, magnetic collector, or vacuum cleaner for all cleaning operations (especially for removing chips, which may be sharp and hot).**



**Do not use a blow gun to remove machining chips.**  
**Do not use solvents or aggressive detergents for cleaning.**  
**Do not immerse the machine in water or wash it with a water jet.**



**Chips are often very sharp and hot. Do not touch them with your bare hands.**

To maintain the efficiency of the machine and its components, it is necessary to carry out maintenance.

Below are the most important maintenance tasks, which can be classified according to their frequency as daily, weekly, monthly, and semi-annual tasks.

Failure to perform the prescribed tasks will result in premature wear and tear and reduce the performance of the machine.

 8.1  DAILY MAINTENANCE

- Clean the machine as normal to remove any chips that have accumulated (collect them in bins).
- Clean the cutting fluid outlet holes to prevent excess fluid from accumulating.
- Check that the motor ventilation grilles are clear.
- Check and fill the cutting fluid reservoir.
- Check that the band is not worn and/or the teeth broken.
- Check that the protective covers, safety devices, and stop mechanisms are working properly.

 8.2  WEEKLY MAINTENANCE

- Thoroughly clean the machine, removing any chips from the cutting fluid reservoir (collect them in containers).
- Remove the pump from the cover, clean the suction filter and the cutting fluid suction area.
- Clean the band guides (bearing and cutting fluid outlet holes).
- Clean the band pulley housings and the band sliding surfaces on the pulleys.
- Check that the screws are tight.

 8.3  MONTHLY MAINTENANCE

- Coat exposed parts with a protective oil film.
- Drain the cutting fluid (see section 7.3).
- Check that the belt guide components are working properly.
- Check that the screws on the motor, pump, and protective covers are tight.
- Check the power cable and replace it if necessary.

 8.4  SIX-MONTHLY MAINTENANCE

- Test the continuity of the equipotential protection circuit.

 8.5  ANNUAL MAINTENANCE

- Drain the motor reducer (use W90 type reducer oil).

 8.6  TAKING THE MACHINE OUT OF SERVICE

If the band saw is not to be used for an extended period of time, it is recommended to proceed as follows:

1. Disconnect the plug from the power supply.
2. Loosen the band.
3. Move the bow to the rest position ("LOW" position).
4. Release the return spring.
5. Empty the cutting fluid reservoir.
6. Carefully clean and lubricate the machine.
7. Cover the machine if necessary.

## 9 EXPLODED VIEW

## EXPLODED VIEW PSR200AVE (VIEW 01)

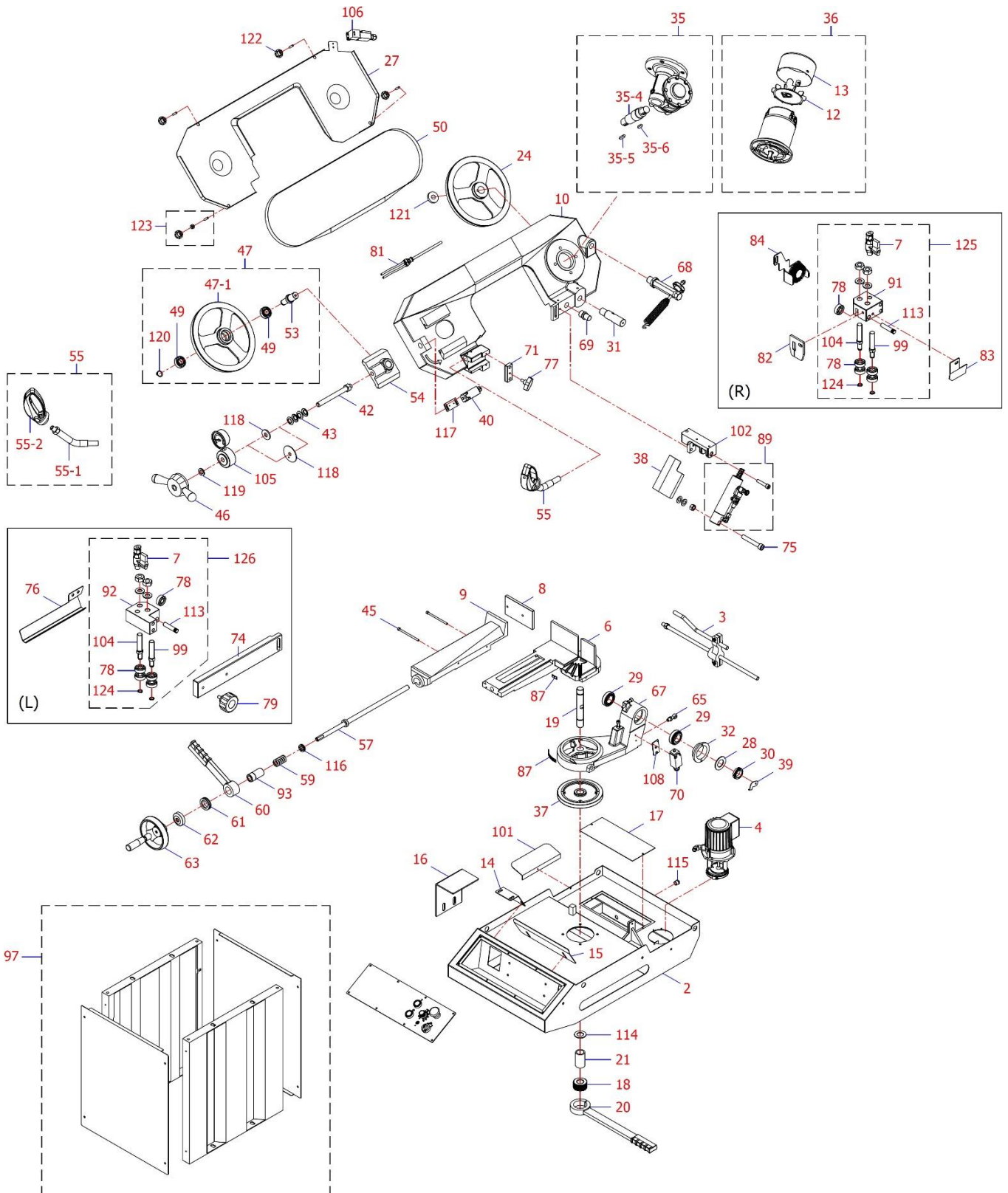

## PARTS LIST EXPLODED VIEW PSR200AVE (VIEW 01)

Part	Description	Quantity
002	FRAME	1
003	CUTTING STOP	1
004	CUTTING FLUID PUMP	1
006	BASE VISE	1
007	CUTTING FLUID TAP	2
008	MOBILE VISE JAW	1
009	MOBILE VISE	1
010	BOW	1
012	FAN MOTOR	1
013	ENGINE FAN COVER	1
014	BASE SUPPORT VISE	1
015	FRONT PLATE CUTTING FLUID	1
016	CUTTING PIECE SUPPORT	1
017	GRID	1
018	BOW TIGHTENING LEVER NUT	1
019	BOW TIGHTENING LEVER AXLE	1
020	BOW TIGHTENING LEVER	1
021	SPACER FOR BOW CLAMPING LEVER AXLE	1
024	DRIVE PULLEY	1
027	MOBILE BAND HOUSING	1
028	BOW AXLE WASHER	1
029	BOW SUPPORT BEARING 32006	2
030	BOW AXLE NUT M30	1
031	BOW AXLE	1
032	BOW ADJUSTMENT SUPPORT	1
035	REDUCER ASSEMBLY	1
035-4	REDUCTOR SHAFT	1
035-5	KEY 7x7x35	1
035-6	KEY 7x8x22	1
036	ENGINE ASSEMBLY	1
037	BOW SUPPORT PIVOT	1
038	HYDRAULIC CYLINDER COVER	1
039	ELECTRIC SAFETY LOCKING STOP AT END OF CUT	1
040	ELECTRIC SAFETY LOCK FOR TAPE TENSION	1
042	BAND TENSION FLYING SCREW M16	1
043	TENSION BELLEVILLE WASHER	4
045	ADJUSTING SCREW BLOCK VISE	2
046	TENSION WHEEL BAND	1
047	TENSION PULLEY ASSEMBLY	1
047-1	TENSION PULLEY	1
049	BEARING AXLE TENSION PULLEY 2Z/6205	2
050	BAND 2080 x 20 x 0.9 mm	1
053	TENSION PULLEY AXLE	1
054	BAND TENSION SUPPORT	1
055	HANDLE + ARCH ARM	1
055-1	BOW ARM	1
055-2	BOW HANDLE	1
057	WHEEL FOR VISE	1
059	VISE SPRING	1
060	QUICK-RELEASE LEVER FOR CLAMP	1
061	BEARING FOR QUICK-RELEASE LEVER FOR VISE 51106	1
062	VISE SUPPORT BUSHING	1
063	VISE HANDLE	1
065	SCREW + NUT TO HOLD THE SPRING ARCH	1
067	BOW SUPPORT	1
068	BOW SPRING ASSEMBLY	1
069	CUTTING END STOP	1
070	ELECTRIC SAFETY LOCK AT END OF CUT	1
071	MOBILE FRONT BAND GUIDE SUPPORT BLOCK	1
074	MOBILE FRONT BAND GUIDE SUPPORT	1
075	HYDRAULIC CYLINDER FASTENING BOLT	1
076	MOBILE FRONT BAND GUIDE PROTECTION	1
077	CLAMPING HANDLE FOR MOBILE FRONT BAND GUIDE	1
078	BAND GUIDE BEARING 608	10
079	MOBILE FRONT TAPE GUIDE HANDLE	1
081	CUTTING FLUID HOSE	1
082	FIXED REAR BAND GUIDE COVER	1
083	FIXED REAR BAND GUIDE PROTECTION	1
084	BRUSH	1
087	BOW GRADUATION	1
089	HYDRAULIC CYLINDER	1
091	FIXED REAR BAND GUIDE	1

092	MOBILE FRONT TAPE GUIDE Band	1
093	WISE SPACER	1
097	BASE	1
099	LOWER PIVOT AXLE BAND GUIDE	2
101	BACK PLATE CUTTING FLUID	1
102	HYDRAULIC CYLINDER SUPPORT	1
104	UPPER PIVOT AXLE TAPE GUIDE	2
105	BAND TENSION GAUGE	1
106	ELECTRIC SAFETY LOCK MOBILE TAPE COVER	1
108	SUPPORT PLATE FOR ELECTRIC SAFETY LOCK AT END OF CUTTING	1
113	PIN	2
114	WHEEL WHEEL WHEEL WHEEL WHEEL WHEEL WHEEL WHEEL WHEEL WHEEL WHEEL WHEEL WHEEL W	1
115	BLOODLETTING SCREW 3/8PT	1
116	BEARING 1629	1
117	ELECTRIC SAFETY LOCK SUPPORT TENSION BAND	1
118	ELECTRIC SAFETY LOCKING PLATE TENSION BAND	1
119	BEARING 1629	1
120	CIRCLIP S20	1
121	WASHER MOTOR PULLEY	1
122	MOBILE BAND HOUSING FASTENING NUT	3
123	MOBILE BAND COVER FASTENING ASSEMBLY	1
124	CIRCLIP S8	4
125	COMPLETE FIXED REAR TAPE GUIDE	1
126	COMPLETE MOBILE FRONT TAPE GUIDE	1

## EXPLODED VIEW OF PSR200AVE CONTROL PANEL (VIEW 02)

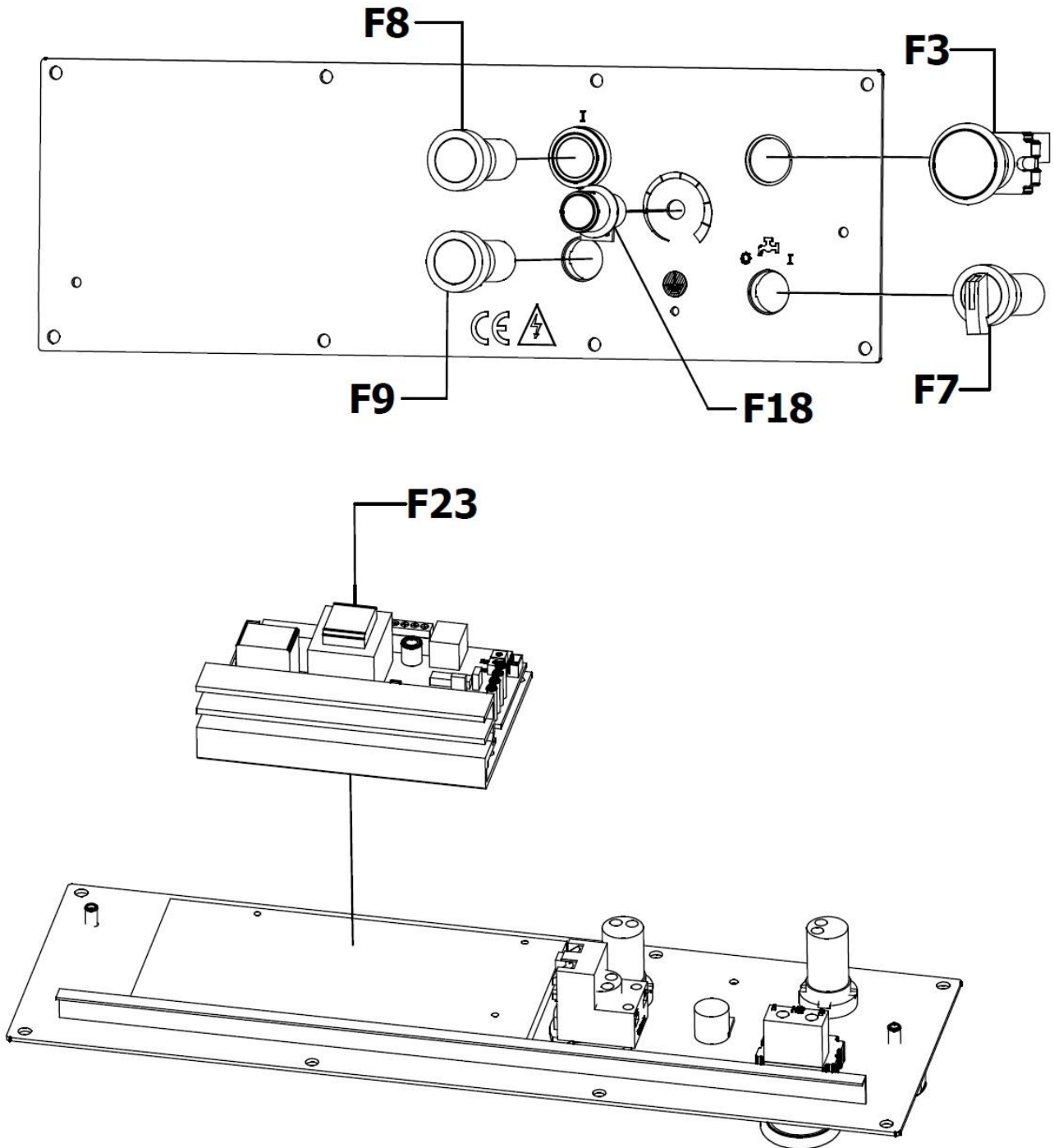

## PARTS LIST EXPLODED VIEW PSR200AVE CONTROL PANEL (VIEW 02)

Part number	Reference	Description	Quantity	Note
F3		HANGING PUNCH STOP	1	
F7		LIQUID CUT-OFF SWITCH	1	
F8		GREEN START BUTTON "I"	1	
F9		RED STOP BUTTON "0"	1	
F18		BAND SPEED POTENTIOMETER	1	
F23		VARIATOR	1	

## 10 ELECTRICAL DIAGRAM

PSR200AVE WIRING DIAGRAM (VIEW 03)

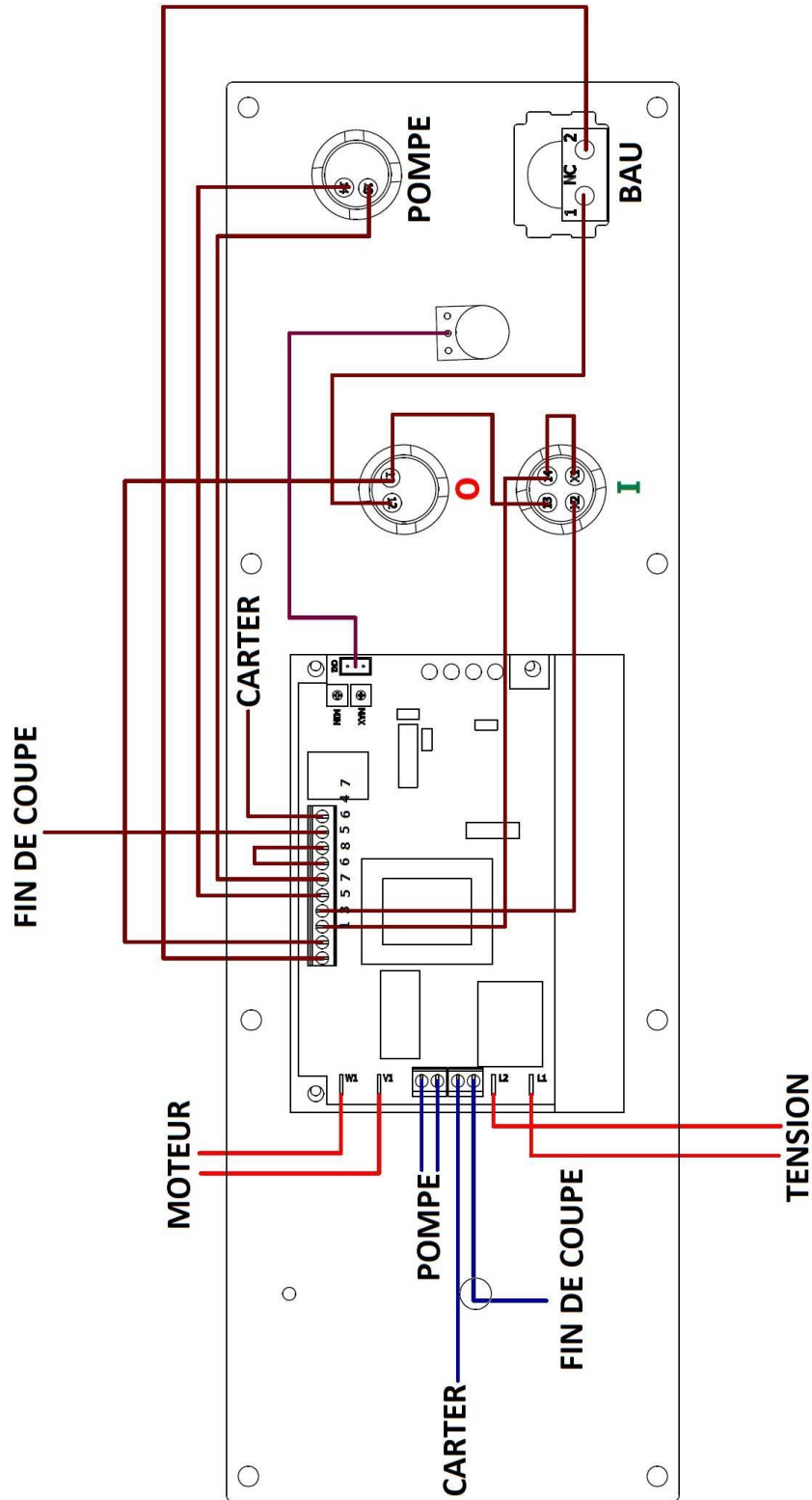

## 11 NOISE LEVEL

The noise level emitted by this machine during operation will depend on the type of material being ground and the type of grinding wheel. For this reason, the measurement data is relative.

The risk of hearing damage to the operator depends on the length of exposure to noise.

The operator must wear ear defenders or other appropriate personal protective equipment when the sound power exceeds 85 dB(A) in the workplace.

- Sound pressure level (1 m at no load):  
**L<sub>pA</sub> = 70 dB(A)**
- Sound power level (1 m without load):  
**L<sub>wA</sub> = 78 dB(A)**

The sound power calculation was performed taking into account factors such as: reverberation at the test site, ground noise absorption, and other factors that may interfere with measurements. This estimate allows us to state that the degree of error in the values obtained would be around 3 dB(A).

The values given are emission levels and not necessarily levels that allow for safe working. Although there are correlations between emission levels and exposure levels, these cannot be used reliably to determine whether additional precautions are necessary. Parameters that influence actual exposure levels include workshop characteristics, other sources of noise, etc., i.e., the number of machines and neighboring manufacturing processes. In addition, permissible exposure levels may vary from country to country. However, this information allows the machine user to make a better risk assessment.



## 12 ENVIRONMENTAL PROTECTION

Your machine contains many recyclable materials.  
This logo indicates that used machines must not be mixed with other waste.

This ensures that machines are recycled under the best conditions, in accordance with European Directive 2012/19/EU on waste electrical and electronic equipment.

Contact your local council or dealer to find out where your nearest collection points for used machines are located.

Thank you for your cooperation in protecting the environment.



## 13 WARRANTY

If the machine is covered by warranty, it must be serviced exclusively by an authorized after-sales service center.

The machine warranty is valid for 2 years from the date of purchase by the user.

This product benefits from an additional 2-year warranty extension, provided that the user registers the product on the PEUGEOT OUTILS PROFESSIONNELS website ([www.peugeot.outils-pro.com](http://www.peugeot.outils-pro.com)) within 30 days of the date of purchase. This warranty extension is subject to the same conditions as the initial warranty.

Accessories and consumables are not covered by the warranty.

It is important to keep the invoice, which serves as the warranty certificate.

The warranty is limited to the repair or replacement of defective parts free of charge, after evaluation by the manufacturer.

For any requests for information or spare parts relating to the machine, it is essential to provide the exact information shown on the nameplate.

The warranty does not cover damage caused by the user or by a repairer not approved by Tivoly.

Link to the General Warranty Terms and Conditions:



# CE AL DECLARATION OF CONFORMITY "ORIGINAL"

The undersigned (Manufacturer/Importer):

**TIVOLY**

**266 ROUTE PORTES DE TARENTEISE 73790 TOURS-EN-SAVOIE**

Declares that the following new machine:

- Designation: GRAVITATIONAL BAND SAW
- Brand: PEUGEOT PROFESSIONAL TOOLS
- Model: PSR200AVE
- Reference: PPM00300002
- Serial number:

Complies with applicable harmonized legislation:

- **Machinery Directive 2006/42/EC (until January 19, 2027)**
- **EU Regulation 2023/1230 (from January 20, 2027)**

Complies with the essential safety requirements applicable to it:

- **Low Voltage Directive 2014/35/EU**
- **Electromagnetic Compatibility Directive 2014/30/EU**
- **WEEE Directive 2012/19/EU**
- **RoHS-2 Directive 2011/65/EU**
- **REACH 1907/2006**
- **Noise Directive 2003/10/EC**
- **Vibration Directive 2002/44/EC**

Done at TOURS-EN-SAVOIE  
On

Stéphane Le Mounier  
Managing Director



Person authorized to compile the technical file:

- Mr. LE MOUNIER – TIVOLY – 266 ROUTE PORTES DE TARENTEISE 73790 TOURS-EN-SAVOIE

	TIVOLY: Registered office: 266 ROUTE PORTES DE TARENTEISE 73790 TOURS-EN-SAVOIE www.peugeot-outils-pro.com	USER SERVICE Tel: +33(0)4 79 89 59 00
	In its ongoing effort to improve the quality of its products, TIVOLY reserves the right to modify their characteristics. The information, photos, exploded views, and diagrams contained in this document are not contractual.	Published by april 2026 PSR200AVE manual