



Get a free 2-year warranty



DE / FR / PT / SP

# COLD SAW MACHINE WITH SAW BLADE PTMFS315S

IN GOOD HANDS

TRANSLATION OF ORIGINAL INSTRUCTION MANUAL





## WHO ARE WE?

**Peugeot Professional Tools** was born out of several obvious considerations.

The first was to combine the know-how of **Peugeot**, which has mastered the art of cutting since 1810, with the expertise of **Tivoly**, a metalworker since 1917, in order to create a wide range of machines and tools for construction and maintenance professionals.

It was also a natural step to want to serve craftsmen and small businesses driven by strong family and heritage values.

For these professionals, **Peugeot Outils Professionnels** offers machines and tools designed specifically for their needs. **These tools are reliable, durable, and can be repaired in France** and in countries under distribution agreements by local industrial and family partners.

Trustworthy equipment with a longer warranty, logistics, and

**French after-sales service.** The assurance of dealing with the people who assembled these tools and know every part that goes into them inside out.

From exceptional projects to everyday work, these tools are designed to withstand the most demanding conditions and stand the test of time.

**Peugeot Professional Tools** was born out of one obvious fact: that our tools are in good hands. The hands of those who work behind the scenes and give their all to satisfy their customers.

**Since 1810**, many things have changed, but the hands have remained the same. The hands of enthusiasts, craftsmen, dedicated technicians and installers, workers who are proud of themselves and their achievements.

**Peugeot Professional Tools: tools in good hands.**

## THANK YOU FOR YOUR PURCHASE.

We are delighted that you have chosen Peugeot Professional Tools. Every detail has been designed to offer you an exceptional experience, and we hope you enjoy using it as much as we enjoyed creating it for you.

Your trust is essential to us, and we are delighted to accompany you every step of the way in your experience with the Peugeot Professional Tools brand.

**Your purchase comes with a 2-year warranty, extendable to an additional 2 years.**

















**To benefit from this, register at [www.peugeot-outils-pro.com](http://www.peugeot-outils-pro.com)**

If you have any questions or need assistance, our team is available to provide you with the best possible service.

To contact our after-sales service, visit [www.peugeot-outils-pro.com](https://www.peugeot-outils-pro.com), call [+33\(0\)4.79.89.59.00](tel:+330479895900), or email [service@peugeot-outils-pro.com](mailto:service@peugeot-outils-pro.com).

Thank you for choosing Peugeot Professional Tools. Your satisfaction is our priority.

## CONTENTS

<b>1</b>	<b>INTRODUCTION</b> .....	<b>4</b>
<b>2</b>	<b>PICTOGRAMS</b> .....	<b>4</b>
2.1	MACHINE SAFETY PICTOGRAMS .....	4
2.2	PICTOGRAMS USED IN THESE INSTRUCTIONS .....	4
<b>3</b>	<b>SAFETY</b> .....	<b>5</b>
3.1	GENERAL SAFETY REQUIREMENTS.....	5
3.2	SPECIAL SAFETY REQUIREMENTS.....	6
3.3	OPERATOR PROTECTION .....	6
<b>4</b>	<b>DESCRIPTION AND OPERATION</b> .....	<b>7</b>
4.1	INTENDED USE OF THE MACHINE.....	7
4.2	FEATURES.....	7
4.3	MACHINE DESCRIPTION.....	7
<b>5</b>	<b>INSTALLATION</b> .....	<b>8</b>
5.1	 PACKAGING .....	8
5.2	 HANDLING AND TRANSPORT.....	8
5.3	 INSTALLATION OF THE MACHINE.....	8
5.4	ASSEMBLY .....	9
5.5	 ELECTRICAL CONNECTION .....	13
5.6	 INITIAL TEST AND CHECK BEFORE FIRST USE .....	13
<b>6</b>	<b>USE</b> .....	<b>14</b>
6.1	 ADJUSTMENTS .....	14
6.2	 CUTTING PROCEDURE.....	15
6.3	CUTTING FLUID .....	16
6.4	REPLACING THE SAW BLADE.....	16
6.5	 SELECTION OF THE TOOTHING OF THE SAW BLADE.....	17
6.6	 PLACING PARTS IN THE VICE .....	18
6.7	 OPERATING INCIDENTS .....	19
6.8	 TAKING THE MACHINE OUT OF SERVICE.....	19
<b>7</b>	<b>MAINTENANCE</b> .....	<b>20</b>
7.1	 DAILY MAINTENANCE .....	20
7.2	 WEEKLY MAINTENANCE.....	20
7.3	 MONTHLY MAINTENANCE .....	20
7.4	 SIX-MONTHLY MAINTENANCE.....	20
7.5	 ANNUAL MAINTENANCE .....	20
7.6	SPECIAL MAINTENANCE .....	21
<b>8</b>	<b>CONSUMABLES</b> .....	<b>21</b>
<b>9</b>	<b>EXPLODED VIEW</b> .....	<b>22</b>
<b>10</b>	<b>ELECTRICAL DIAGRAM</b> .....	<b>26</b>
<b>11</b>	<b>NOISE LEVEL</b> .....	<b>27</b>
<b>12</b>	<b>VIBRATION LEVEL</b> .....	<b>27</b>
<b>13</b>	<b>ENVIRONMENTAL PROTECTION</b> .....	<b>28</b>
<b>14</b>	<b>WARRANTY</b> .....	<b>28</b>
<b>15</b>	<b>DECLARATION OF CONFORMITY</b> .....	<b>29</b>

## 1 INTRODUCTION



**For safety reasons, read these instructions carefully before using this machine.  
Failure to follow the instructions will result in damage to persons and/or the machine.**

This instruction manual is intended for the operator, adjuster, and maintenance technician.

This instruction manual is an important part of your equipment. It provides rules and guidelines that will help you use this machine safely and efficiently. You must familiarize yourself with the functions and operation by reading this instruction manual carefully. For your safety, it is particularly important that you read and observe all recommendations on the machine and in this instruction manual.

These recommendations must be strictly followed at all times when using and maintaining the machine. Failure to follow the safety guidelines and warnings in the instruction manual and on the machine and/or use other than that recommended in the instruction manual may result in machine failure and/or injury.

Please keep this instruction manual with the machine or in a place that is easily accessible at all times for future reference. Ensure that anyone involved in the use of this machine can consult it

periodically. If the instruction manual is lost or damaged, please contact us or your dealer to obtain a new copy.

Always use PEUGEOT OUTILS PROFESSIONNELS components and parts. Replacing components or parts other than PEUGEOT OUTILS PROFESSIONNELS may cause damage to the machine and endanger the operator.

This manual describes the safety instructions to be followed by the user. It is the responsibility of the employer or user, in accordance with Article L.4122-1 of the Labor Code, to take care of their health and safety and that of other persons affected by their actions or omissions, in accordance, in particular, with the instructions given to them.

The employer must carry out an assessment of the specific risks associated with their activity, must train workers in the use of the machine and in the prevention of these risks, and must appropriately inform workers responsible for the use or maintenance of work equipment of the instructions or guidelines concerning them.

## 2 PICTOGRAMS

### 2.1 MACHINE SAFETY PICTOGRAMS

Meaning of the safety pictograms affixed to the machine (keep them clean and replace them when they are illegible or detached):



Wearing protective eyewear is mandatory



Hearing protection must be worn



Safety shoes must be worn



Gloves must be worn



Read the instruction manual carefully



Do not wear loose clothing, wide sleeves, jewelry, bracelets, watches, wedding rings, etc.  
Wear hair nets for long hair



Presence and direction of the teeth of the saw blade



Direction of rotation of the saw blade

### 2.2 PICTOGRAMS USED IN THESE INSTRUCTIONS



Direct danger to persons and damage to the machine.



Possible damage to the machine or its surroundings.



For band replacement and cleaning operations, wear protective goggles and gloves.



Minimum number of personnel required for certain operations.



If necessary, wear respiratory protection to reduce the risk of inhaling hazardous dust.



Note.



Technical skill level: operator, user.



Technical skill level: adjuster, maintenance.



Technical skill level: maintenance technician.



**Electrical work must be carried out by personnel who are qualified and authorized to perform low-voltage electrical work.**

### 3 SAFETY

#### 3.1 GENERAL SAFETY REQUIREMENTS



**To reduce the risk of fire, electric shock, mechanical shock, and personal injury when using power tools, follow basic safety precautions.**

This instruction manual only takes into account reasonably foreseeable behavior.

Our machines are designed and manufactured with the operator's safety in mind.

The machine must not be used by young workers under the age of eighteen.

We accept no liability for any damage caused by inexperience, incorrect use of the machine and/or damage to it and/or failure to comply with the instructions and safety rules contained in this instruction manual.

As a general rule, accidents always occur as a result of misuse or failure to read the instruction manual.

We remind you that any modification to the machine will result in our withdrawal of liability.

Check the presence, condition, and operation of all guards before starting work.

Ensure that moving parts are working properly, that there are no damaged components, and that the machine is in perfect working order during start-up.

Only competent and authorized personnel are permitted to repair or replace damaged parts.

Keep the work area clean and tidy.

Ensure that the entire work area is visible from the work position. Cluttered work areas and workbenches are a potential source of injury.

Do not use the machine outdoors when weather and environmental conditions do not permit it or in very humid locations. Reserve it for indoor use, in a dry, well-ventilated area free from flammable liquids or gases.

Position the machine in a sufficiently lit work area.

Do not allow unauthorized persons, especially children and animals, to touch the tools or electrical cables, and keep them away from the work area.

Turn off the machine when you have finished using it. Always disconnect the power supply.

Never leave the machine unattended while it is running. Only leave the machine when it has come to a complete stop.



Do not force the disc; it will perform better and be safer at the speed for which it is designed.

Do not use discs for work for which they are not intended.



Do not damage the power cord.

Never pull on the power cord to remove it from the electrical outlet.

Keep the power cord away from heat sources, greasy areas, and/or sharp edges.

Protect the power cord from moisture and any potential damage. Check the power cord periodically. If damaged, have it repaired by an authorized repairer.

Defective switches must be replaced by a qualified person or an authorized repairer.

Do not use the machine if the switch does not control the stop or start functions.



Do not overestimate your strength.

Always maintain a stable position and good balance.

Be aware of what you are doing and use common sense.

Do not use the machine when tired.

Always use both hands to operate this machine.

The use of any accessories other than those described in the instruction manual may present a risk of injury to persons.

The user is responsible for their machine and must ensure that:

- The chainsaw is used by people who have been instructed in its use and are authorized to do so.
- Safety rules have been followed.
- Users have been informed of the safety rules.
- Users have read and understood the instruction manual.
- Responsibilities for maintenance and any repairs have been clearly assigned and observed.
- Defects or malfunctions were immediately reported to an authorized repairer or your dealer.
- The chainsaw must be used in the areas of application described in this manual.
- Any use other than that specified in this instruction manual may constitute a hazard.
- Mechanical and/or electrical guards must not be removed or bypassed.
- No modifications and/or conversions must be made.

PEUGEOT OUTILS PROFESSIONNELS declines all responsibility for damage caused to persons, animals, or objects as a result of failure to comply with the instructions and safety rules contained in this instruction manual.

### 3.2 SPECIAL SAFETY REQUIREMENTS



#### Special safety requirements for the band saw.

Before use, the machine must be correctly assembled.  
Do not plug in if the saw is not placed on a flat, stable surface, free of obstacles and well lit.  
Check that the saw blade is securely fastened.  
Do not use a damaged or deformed saw blade to avoid kickback.  
Do not operate the saw blade when the saw blade guards are removed.  
Check that the movable saw blade guard is working properly.  
Never block the movable saw blade guard.  
Ensure that no wrenches are left on the chainsaw before starting it.  
Do not use this machine to cut non-ferrous metals, building materials, wood, PVC, or derivatives.  
Ensure that the choice of cutter, teeth, and feed speed are appropriate for the material and cross-section of the workpiece to be cut.  
Do not strike the cut-off saw against the workpiece, but apply pressure gradually.  
Do not start cutting with the saw pressed against the workpiece.  
In all cases, remain focused on the task at hand.  
For all operations involving a risk of cutting, burning, pinching, snagging, entanglement, or crushing, in particular when loading and unloading workpieces, changing the saw blade, or handling the workpiece and vise, stop the machine and wear protective gloves.  
Do not touch the saw blade while it is moving.  
It is very important to prevent cutting fluid from spilling onto the surrounding area, as this creates a slipping hazard.  
Always wear protective eyewear.  
Keep your hands away from the cutting areas when the machine is in operation.  
Never hold workpieces by hand; clamp them securely using the vise.  
Use appropriate cutting speeds.  
Wear hearing protection.  
Ensure that no one is in the path of debris and sparks caused by cutting.

Wear respiratory protection to reduce the risk of inhaling hazardous dust.  
When cutting is complete, return the head to its starting position (rest, upward).  
When the machine is stopped, the saw blade continues to rotate for a few seconds before coming to a complete stop.  
The cutter can become very hot during operation. Wait for the cutter to cool before replacing it.  
Do not add additional accessories for operations for which they are not designed.  
Using an inappropriate accessory increases the risk of accidents.  
Always keep the saw blade clean.  
Do not clean the saw blade while it is moving.  
Before performing any maintenance or servicing, set the speed switch to the "0" position.  
When cleaning, wear protective goggles and gloves, and use a brush and a clean, dry cloth.  
Always keep the work surface of the chainsaw clean and uncluttered.  
Keep the fan cover clean and uncovered to ensure the machine operates correctly.  
Replace the vise base when it is worn.



Accidents are usually the result of:

- Lack of accessories that allow the workpiece to be held securely.
- Disorder: accessories, if any, are not stored away and the operator cannot find them, so does without them.
- Inappropriate or dangerous operating procedures.
- Insufficient training, learning, and/or experience of operators in the use of the machine.
- Absence of protective covers during machine use.
- Ill-fitting clothing, lack of safety glasses for certain tasks.

### 3.3 OPERATOR PROTECTION



#### For operator safety, ensure that non-working parts are always covered by a protective guard.

This machine is designed for a single operator.  
The operator must wear appropriate personal protective equipment:

- Safety glasses.
- Hearing protection.
- Safety shoes.
- Protective gloves.



The operator must wear close-fitting clothing and, if necessary, hair coverings for long hair.

The operator must not wear, for example:

- Loose-fitting clothing with wide sleeves.
- Bracelets, watches, wedding rings, jewelry.
- Any other objects that could become caught in the moving parts of the machine.



## 4 DESCRIPTION AND OPERATION

### 4.1 INTENDED USE OF THE MACHINE

The PTMF315S workshop cutting machine is designed and manufactured solely for occasional use in cutting ferrous metals (steel, iron, cast iron), either profiles or solid pieces, using a saw blade.

Under proper conditions of use and maintenance, safe operation and work are guaranteed for several years. To do this, explore the machine's various functions.

The manufacturer declines all responsibility in the event of misuse or cutting of materials other than those mentioned above.

**Do not use this machine to cut non-ferrous metals (copper, aluminum, lead, zinc, tin, brass, stainless steel, etc.), building materials (concrete, cinder blocks, paving stones, stone, etc.), wood, PVC, or derivatives.**

### 4.2 FEATURES

- Head and clamp swivel 45° to the left and right
- Quick-release vise
- Double anti-burr clamp
- Movable jaw for 45° cutting to the right
- Removable saw blade guard
- Saw blade lubrication system with pump
- Oil bath gearbox transmission
- Steel cast iron frame
- Control arm equipped with a trigger switch
- Very low voltage 24 V controls
- Locking punch stop
- Speed selector
- IP 54 electrical insulation
- Supplied with base, saw blade (6 mm pitch) and 540 mm cutting stop

Capacities Cutting (mm)	Round	Square	Rectangular	Opening Vise (mm)	Dimensions milling cutter saw (mm)	Rotation speed (rpm)	Power supply	Motor power (kW)	Weight (kg)	Dimensions (W x H x D) (mm)
90°	100	82	110 x 70	120	315 x 2.5 x 32	44 / 88	400 V three-phase	1.3 / 1.9	175	1020 x 1830 x 990
45°G	90	80	85 x 70							
45°R	90	80	85 x 70							

### 4.3 MACHINE DESCRIPTION

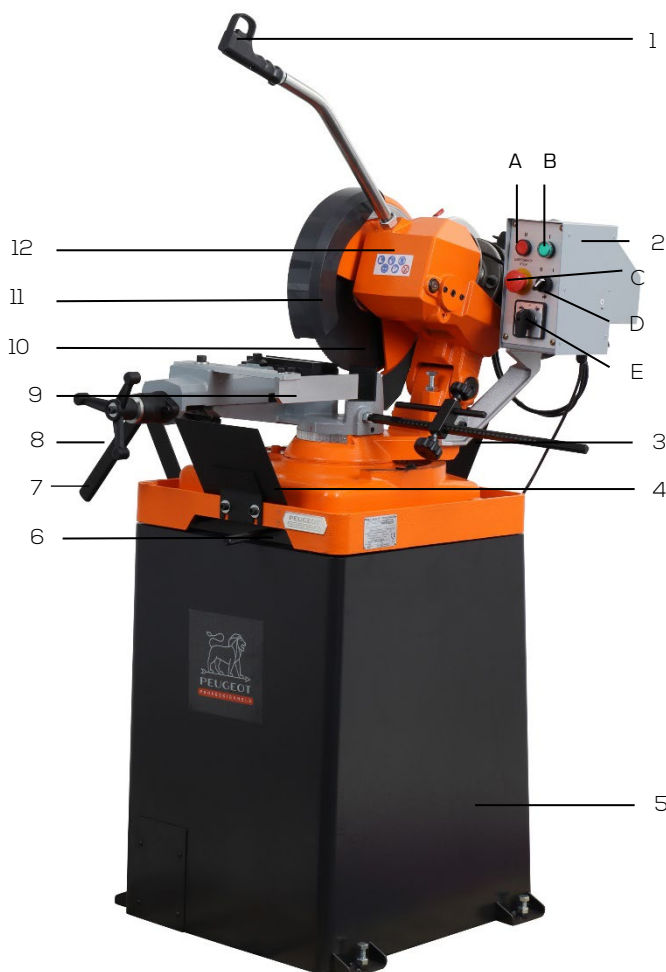

1. Lowering arm with switch handle
2. Control panel with:
  - A: "stop" button
  - B: "start" button
  - C: lockable punch stop
  - D: "on/off" switch for cutting fluid pump
  - E: Speed switch
3. Cutting stop
4. Splash guard
5. Base with lubrication system
6. Head locking lever
7. Quick-release lever
8. Vise wheel
9. Vise
10. Saw cutter
11. Movable saw blade guard
12. Head

Figure 1

## 5 INSTALLATION

### 5.1 PACKAGING



**A small moisture-proof bag may be included in the packaging. Keep out of reach of children and dispose of it.**

The workshop chainsaw is packaged without cutting fluid in a cardboard box on a pallet, facilitating handling, transport, and storage.

Use a pallet truck or forklift to move the machine. Several people are required to set it up.

When unpacking, remove each part of the machine, check its overall condition, and then proceed with assembly.

Check that the machine is clean.

If the product does not appear to be in good condition or if any parts are broken or missing, contact your dealer.

Keep the instruction manual for future reference.

### 5.2 HANDLING AND TRANSPORT



**The operations described below must be performed by qualified and authorized personnel.**



Given the weight (175 kg) and dimensions of the machine, handling and installation must be carried out using appropriate means and with the assistance of several people.

To lift the machine, use a slinging system (e.g., polyester cables of adequate capacity with rings).

Check that the moving parts are locked and lift the machine with the utmost care; keep people who are not involved in the lifting operation away.

### 5.3 INSTALLATION OF THE MACHINE



**The operations described below must be performed by qualified and authorized personnel.**

#### Installation environment:

- Power supply voltage in accordance with the machine's specifications.
- Ambient temperature between +5°C and +35°C.
- Relative humidity not exceeding 90%.
- Sufficient ventilation at the installation site.
- Work area sufficiently lit for safe working: lighting must be 500 LUX.

Consider the location of the machine in the room; it must allow for easy movement and maneuvering. Maintain a minimum distance of 800 mm between the rear of the machine and the wall.

Before installation, fully assemble the base by joining the 4 sides and check all fastenings (see section 5.4 "Assembly").

Secure the machine to the base using the 4 fixing bolts.

Place the machine on a concrete floor approximately 200 mm thick and 100 mm wider than the base on each side. Ensure that the floor surface is level and smooth. Secure to the floor using the appropriate screws driven into the concrete. Before tightening the screws, check that the Cold saw machine with saw blade is level.

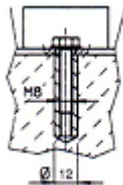
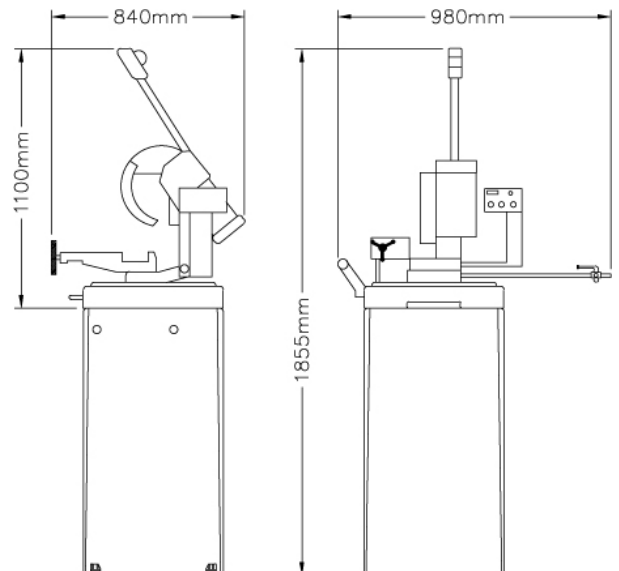

Dimensions:

## 5.4 ASSEMBLY

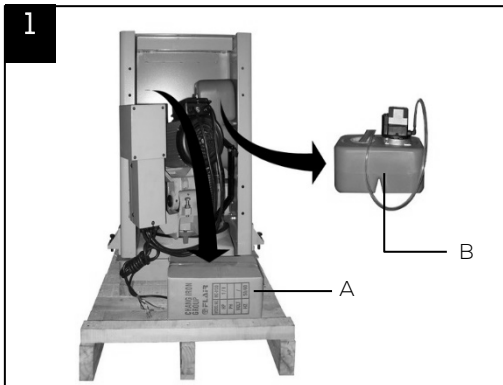

The procedures described below must be carried out by qualified and authorized personnel.

**Unpacking**

Remove the packaging. Remove all accessory parts (A) and the lubrication system (B) from the pallet (they will be assembled at the end of the installation).

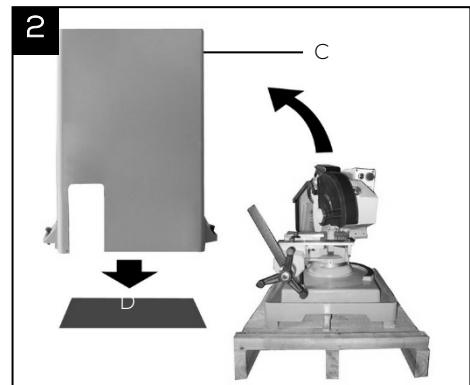

Carefully lift the base (C) and mount it in the machine location (D).

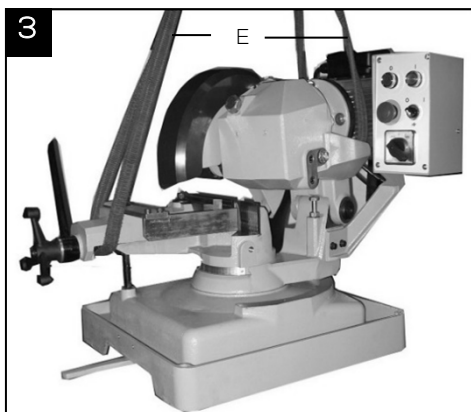
**Mounting the machine on the base**

First method: Use straps. Carefully wrap the straps (E) around the movable vise and the motor.

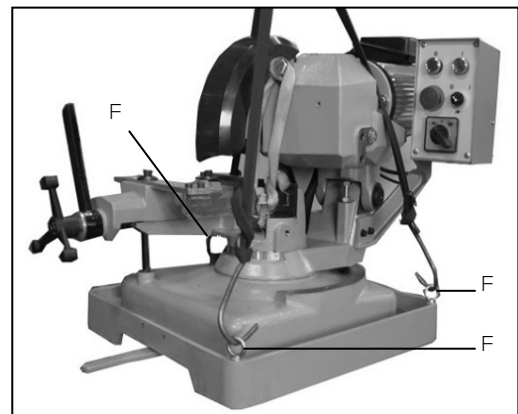

Second method: Use eyelet pins. Attach the three-point lifting pins to the base of the machine and attach a three-point strap with hooks (F).

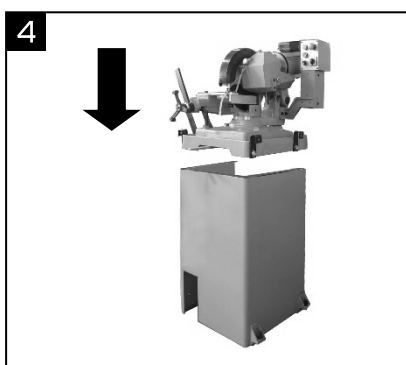

Lift the machine using a hoist to place it on the base.

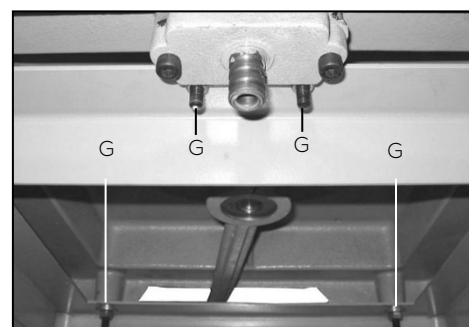

Align the 4 holes (G) on the underside of the machine.  
Screw the bolts into these holes (L).  
Place the nuts on the bolts and tighten them securely.

Install the lubrication system plate:

- Place the plate (H) in the base as shown in the image and secure with the 2 M8x12 screws (I).

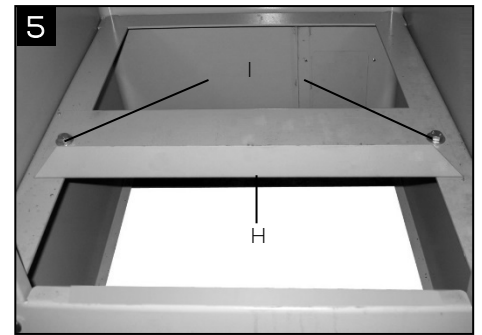

- Remove the screw (J) from the gearbox (used only for transport).

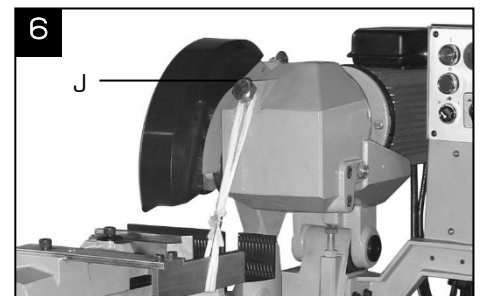

- Screw the arm (L) with the switch handle (K) into the hole (J) and then lock it in the correct position using the nut.

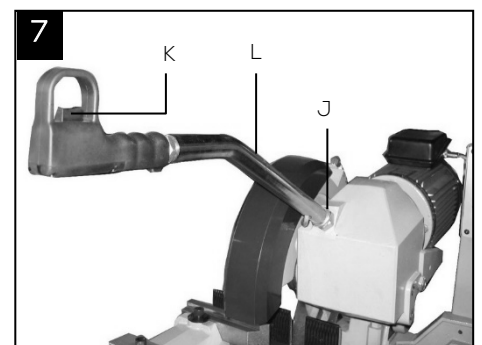

- Plug the control cable into the socket (M) on the motor terminal box. Tighten the connection (N).

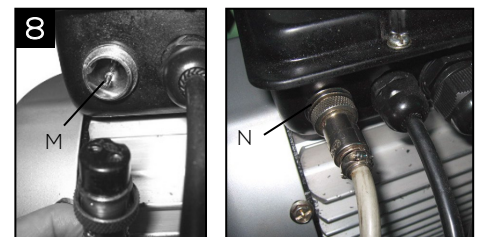

Mount the support bracket (P) on the left side of the machine base:

- Lightly screw the support bracket to the base using the two M10x25 screws (O).
- Align the roller with the bottom of the vice.
- Tighten the screws (O).

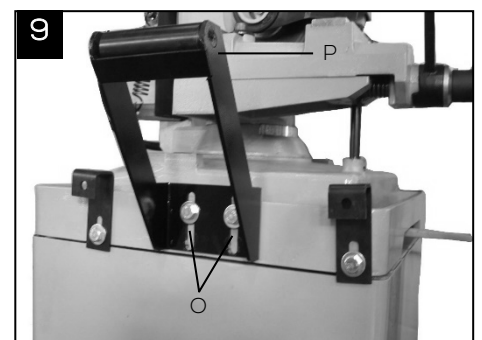

Attach the cutting stop (R) to the right side of the machine base:

- Insert the bar into the hole in the machine base and secure it with the nut (O).
- Adjust the stop toward the saw blade so that it is in the "0" position on the mark.

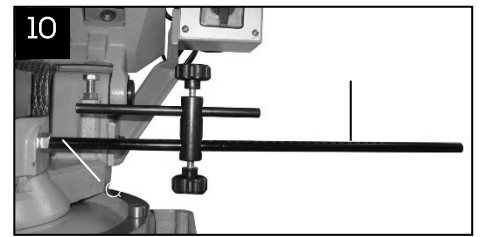

Mounting the cover (S) to the base:

- Place the cover on the cutout (used for transport only) and secure with M5x6 screws.

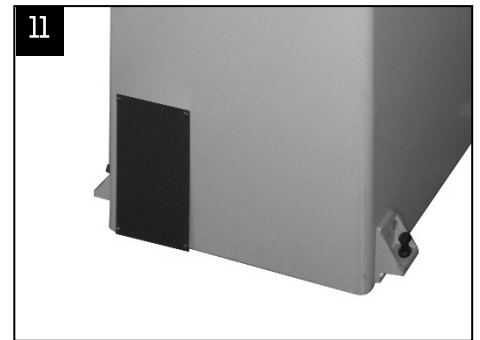

Assembling the lubrication system:

- Secure the pump (X) to the tank (T) using two M6x20 screws (U).
- Attach the hose (W) to the pump and the saw blade guard connection using 2 hose clamps (V).

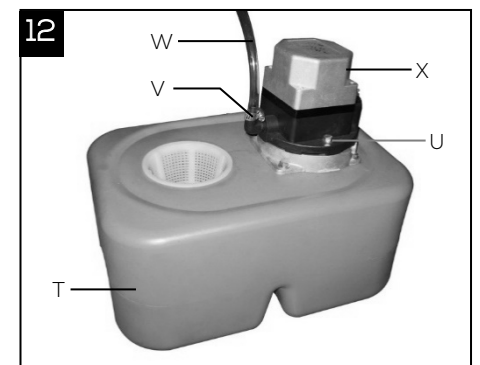

- When installing the pump system (1A), ensure that the pump (X) is correctly positioned inside the machine base.
- Screw the crossbar of the plate (H) to the machine base using the 4 M8x25 screws.

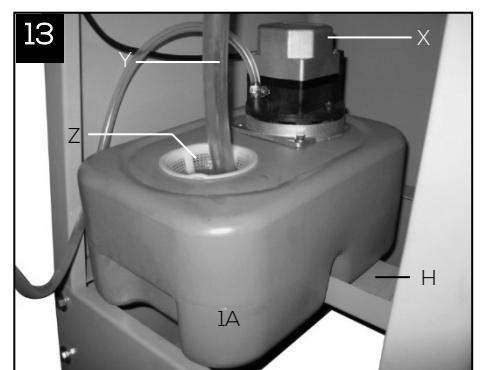

- Attach the return pipe (Y) underneath the machine (1B), ensuring that the return pipe fits into the tank filter.
- Screw the cover plate (1C) to the base using the screws (1D).

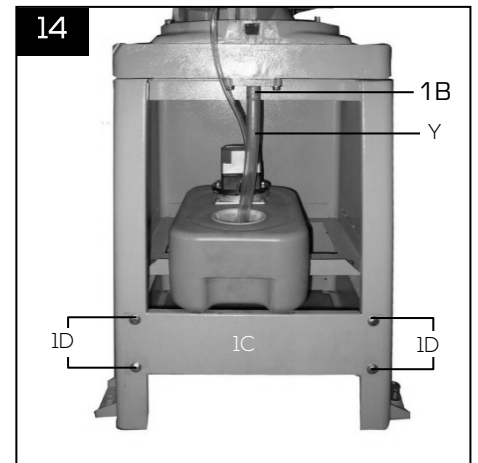

- Secure the front splash guard (1E) to the base of the machine using the 2 M8x16 screws (1F).
- Ensure that the guard does not touch the lower part of the vise.



- Attach the rear splash guard (1G) to the machine. It can be moved as needed, for example for miter cuts.

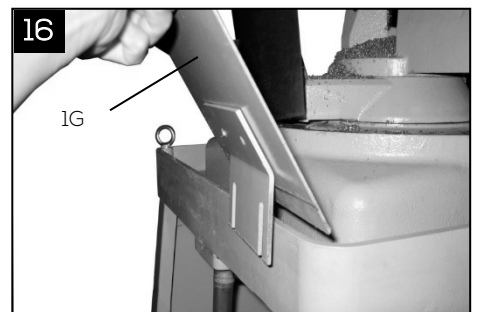

5.5  ELECTRICAL CONNECTION

**Electrical work must be carried out by qualified personnel authorized to perform low-voltage electrical work.**



**ELECTRICAL PRESENCE**

Ensure that the power supply voltage of the installation corresponds to that of the machine.

Connect the machine to the power supply using the power cable located at the rear of the control panel.

Use a socket that complies with the "EN 60309-1" standards for the connection.

Check that the power outlet of the installation is compatible with the machine's plug.

Check that the electrical installation to which the machine will be connected is properly earthed in accordance with current safety standards.

We remind the user that there must always be a magnetothermal protection device upstream of the electrical installation to protect all conductors against short circuits and overloads.

This protection must always be selected based on the electrical characteristics of the machine, as specified on the nameplate:

- Voltage: 400 V three-phase
- Frequency: 50 Hz
- Current: 3.5/4.2 A
- Motor power: 1.3/1.9 kW



Connect an approved electrical plug (NF EN 60309-1) to the end of the power cable of the cold saw machine with a saw blade, in accordance with current regulations. Insert the yellow-green protective conductor into the corresponding terminal marked with the earth logo.



**Use of the machine with a damaged cable is strictly prohibited. Regularly check the condition of the power cord, switches, and cable gland.**



**Do not remove the plug from the power outlet by pulling on the cord; pull only on the plug.**



**Check the direction of rotation of the saw blade, reverse two phases if necessary. The warranty does not cover damage caused by incorrect connection.**

The pictogram indicating the direction of rotation of the saw blade is located on the protective cover, as is the pictogram indicating the direction of installation of the saw blade.

 5.6  INITIAL TEST AND CHECK BEFORE FIRST USE

- Check that the machine is securely attached to its base, that the base is attached to the pedestal, and that the pedestal is attached to a sufficiently flat and non-slip surface so that it is as stable as possible.
- Check that the moving parts are working properly and that there are no damaged components.
- Check that the guards are present, intact, and in good working order.
- Check the condition of the saw cutter.
- Check the descent of the cutter head and the cutter guard.
- Check that the machine runs perfectly when idle.

## 6 USE



**Before starting the machine, familiarize yourself with the controls.**



**Before performing any maintenance or servicing, set the speed switch to the "0" position.**

 6.1  ADJUSTMENTS

**Disconnect the machine from the power supply before performing these operations.**

**Operator position**

- The operator stands in front of the machine and can thus operate all the adjustment elements.
- The working height must be 970 mm.

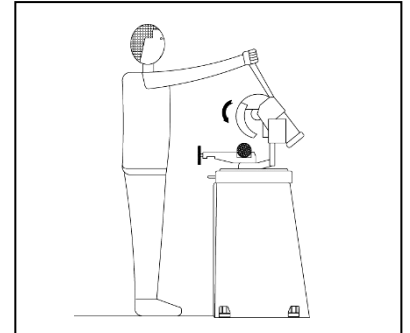
**Angle cuts**

The chainsaw can be used to make 45° left, 45° right, and intermediate angle cuts:

1. Operate the locking lever (A).
2. Turn the head to the desired angle (B).
3. Lock the head firmly in place using the lever (A) to prevent the clamp from changing position during the cut.

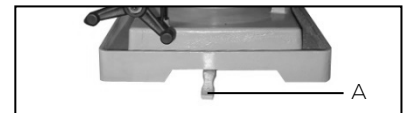
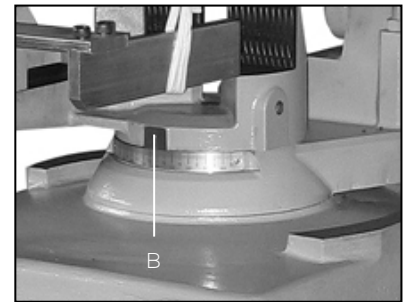
**Clamp assembly**

The machine is equipped with a quick clamping system and an "anti-burr" device:

1. Move the movable clamp towards the workpiece (C) using the crank handle (A). Leave 2-5 mm of clearance between the workpiece and the jaw.
2. The workpiece can then be easily locked or unlocked using the quick-clamping lever (B).

Vise opening: 120 mm max.

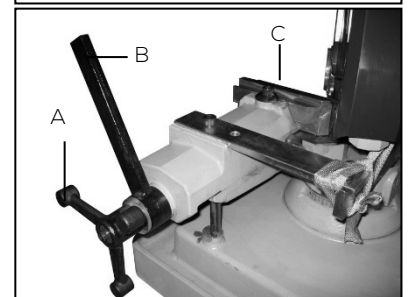
**Clamping the workpiece to be cut**

**Do not place workpieces to be cut on the vise assembly:**

- **During cutting.**
- **When a profile is already inserted in the vise.**

1. Open the vise sufficiently.
2. Measure the workpiece and mark the cutting line.
3. Place the part to be cut between the jaws.
4. Align the workpiece to be cut with the saw blade and the back of the vise.
5. Clamp the workpiece as described above.

## Cutting stop

The length of the piece to be cut can be adjusted using the cutting stop:

1. Select the desired cutting length on the ruler located on the bar (C).
2. Place the workpiece in the vise so that its end touches the stop cam (B), then tighten the adjustment screws (A).
3. Lock the workpiece in the vise.
4. Check the length of the workpiece.

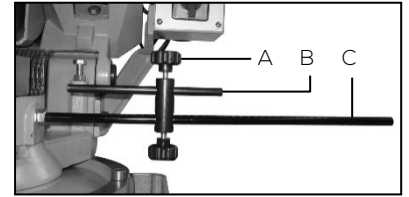

## Head locking lever

If the lever does not lock the head, it is necessary to readjust its position:

- Loosen screw (A), turn lever (C), and retighten screw (A).

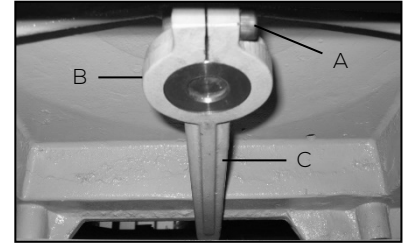

## 6.2 CUTTING PROCEDURE



**Keep your hands away from the cutting areas when the machine is in operation. Before positioning the profile or removing cutting waste, stop the machine.**



**Always use the vice: the parts to be cut must be securely clamped in the vise to prevent them from being thrown out. During cutting, there is a risk of sparks or hot metal debris being projected.**

## Operating cycle

Cutting instructions:

1. Set the head to the desired cutting angle.
2. Open the clamp sufficiently.
3. Adjust the stop.
4. Place the workpiece.
5. Lock the workpiece in place.
6. Select the "HIGH" (hare) or "LOW" (tortoise) speed (C).
7. Turn on the lubricant pump (B).
8. Press the "START" button (A).
9. Grasp the arm (L) and start the machine by pressing the switch (M).
10. Lower the head slowly toward the workpiece to be cut, applying constant and correct pressure.

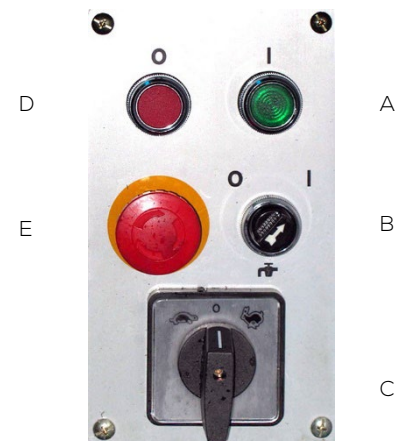

Stopping:

1. Release the switch (F) and the machine will stop.
2. After cutting, return the head to its initial position.
3. Press the "STOP" button (D).
4. Set the speed switch to the "O" position.
5. Open the vise.
6. Push back the piece to be cut or remove it.

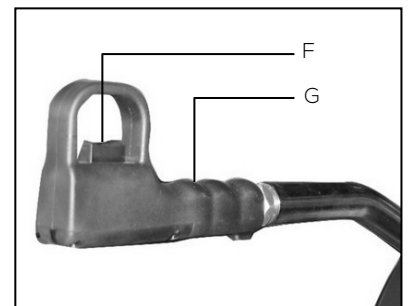

**When cutting is complete, return the head to its starting position (rest, upward).**



Select a saw blade with teeth suitable for the cut profile.

To achieve an excellent cut finish, it is essential to use the anti-burr vise.

### 6.3 CUTTING FLUID

Pour the cutting fluid, consisting of water and soluble oil, into the filling tank located at the rear of the saw blade.  
Dilute the soluble oil according to the percentages specified by the product manufacturer (generally 10% to 15%).

Ensure that there is sufficient coolant to lubricate the cutter saw.  
Tank capacity: 5 liters.

#### Cleaning the lubrication system

1. Remove the filter hose (A).
2. Remove the lubrication system from the machine base.
3. Remove the filter (A).
4. Drain the coolant and clean the reservoir.
5. Replace the filter (A) and install the lubrication system in the machine base.
6. Fill with coolant.



### 6.4 REPLACING THE SAW BLADE



**Perform this operation when the machine head is in the rest position, the saw blade is stopped, and the power supply is disconnected.**



**Never install a damaged, warped, bent, cracked, or chipped saw blade (risk of kickback).**

**Fit a saw blade that complies with the machine's recommendations for use.**

**Replace the saw blade when the teeth are worn or broken to avoid additional vibrations and inaccurate cuts.**



**The saw blade can become very hot during machine operation. Wait for the saw blade to cool before replacing it.**



**Only use saw blades that comply with the original specifications: same diameter, thickness, and bore.**

**Do not use saw blades larger than 315 mm in diameter.**



**Only use saw blades recommended by PEUGEOT OUTILS PROFESSIONNELS with a speed equal to or greater than the speed indicated on the tool's nameplate.**



**Gloves must be worn.**

#### Procedure:

1. Loosen the rod (B) on the movable casing (A) so that it can move freely.
2. Clamp a piece of wood in a vice and press the saw blade against it.
3. Unscrew the screw (C) using the wrench provided; left-hand thread: loosen clockwise.
4. Remove the flange (E) and the saw blade (D).
5. Clean all parts, insert the new saw blade and flange, and tighten the screw.

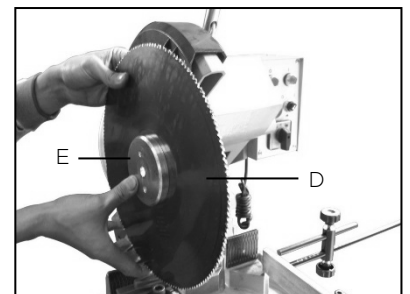
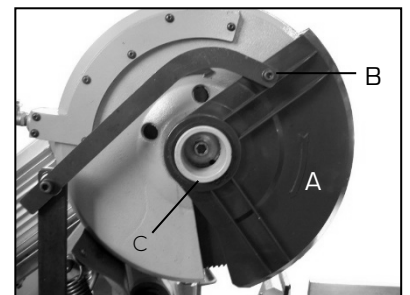

**Ensure that the teeth of the saw blade are facing the correct direction when installing.**

## 6.5 SELECTION OF THE TOOTHING OF THE SAW BLADE

### CLASSIFICATION OF MATERIALS AND SELECTION OF THE SAW BLADE



**Do not use saw blades with dimensions other than those specified.**

Various parameters such as material hardness, shape, thickness, the workpiece to be cut, the choice of saw blade, cutting speed, and head descent speed must be taken into account to achieve optimum cutting quality.

Various problems can be solved more easily if the operator is familiar with these specifications.

#### Choice of saw blade

First, the correct pitch for the material to be cut (number of teeth per inch = 25.4 mm) must be selected according to the following criteria:

- Parts with a small and/or variable cross-section, such as profiles, pipes, and plates, require narrow teeth so that the number of teeth used simultaneously for cutting is between 3 and 6.
- Pieces with large cross-sections and solid pieces require wider tooth spacing to allow for a higher chip volume and better tooth penetration.
- Parts cut in bundles require combined teeth.

#### Cutting speed and feed rate

The cutting speed (m/min) and feed rate (cm<sup>2</sup>/min = distance traveled by the teeth during chip removal) are limited by the heat generated near the tips of the teeth:

- The cutting speed depends on the strength of the material ( $R = N/mm^2$ ), its hardness (HRC), and the dimensions of the highest section.
- An excessively high feed rate (= descent of the head) tends to cause the milling cutter to deviate from the ideal cutting path, producing non-straight cuts in both the vertical and horizontal planes.

The best combination of these two parameters can be seen by directly examining the chips:

- Very fine or pulverized chips indicate that the feed rate and/or cutting pressure is too low (fig. 1).
- Thick and/or blue chips indicate that the saw blade is under too much stress (fig. 2).
- Long, spiral-shaped chips indicate ideal cutting (Fig. 3).

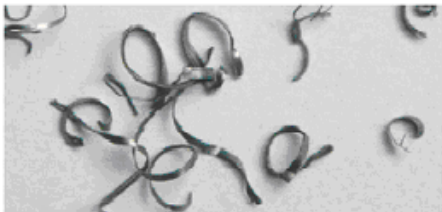

Figure 1

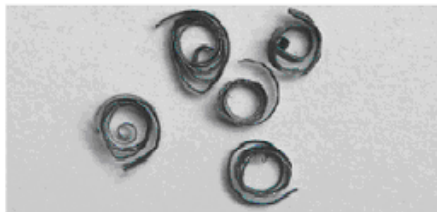

Figure 2



Figure 3

## Characteristics of the saw blade

The most commonly used saw cutters are made of bi-metal, HSS.

## Recommendations for saw cutters

Tubes and profiles	Profile thickness E (mm)	Tooth pitch (mm)	Tooth type*	Recommended speed
	1 to 2	Pitch 3	BW-ACME	2
	2 to 3	Pitch 4	BW-ACME	2
	3 to 4	Pitch 5	C-HELLER	2
	4 to 6	Pitch 6	C-HELLER	2
	7 to 9	Pitch 8	C-HELLER	1
	9 to 12	Pitch 10	C-HELLER	1
	13 to 16	Pitch 12	C-HELLER	1

Solid materials	Solid section (S) (mm)	Tooth pitch (mm)	Tooth type*	Recommended speed
	5 to 10	Pitch 3	BW-ACME	1 and 2
	10 to 15	Pitch 4	BW-ACME	1 and 2
	15 to 20	Pitch 5	C-HELLER	1
	20 to 25	Pitch 6	C-HELLER	1
	25 to 35	Pitch 8	C-HELLER	1
	30 to 40	Pitch 10	C-HELLER	1
	35 to 50	Pitch 12	C-HELLER	1

### \* ACME TEETH:

Tooth sharpening: every other tooth, opposite sides.

Sharpening height: two-thirds of the tooth height.

Cutting tubes and profiles: up to 3 mm thick.

### \* HELLER TOOTHING:

Tooth sharpening: every other tooth, on both sides.

Cutting tubes and profiles: greater than 3 mm thick.

Cutting solid materials: divide the smallest section by 4.

Example: for 90° cuts°

- 50 x 50 mm square

50: 4 = 12.5

Choose a pitch of 12 mm

- Rectangle measuring 60 x 30 mm

30: 4 = 7.5

Choose a pitch of 8 mm



It is advisable to replace the standard saw blade diameter with a smaller diameter:

- 315 mm diameter for cutting tubes and profiles.

- Diameter 275 mm for cutting solid materials.

## 6.6 PLACING PARTS IN THE VICE



**Never hold the parts to be cut by hand.**

To ensure precise cuts, optimum performance, and increased longevity of the saw blade, the figures below show recommendations for clamping parts in the vice according to their shape (for straight 90° cuts).

The parts to be cut must be placed directly between the jaws without any other objects in between.

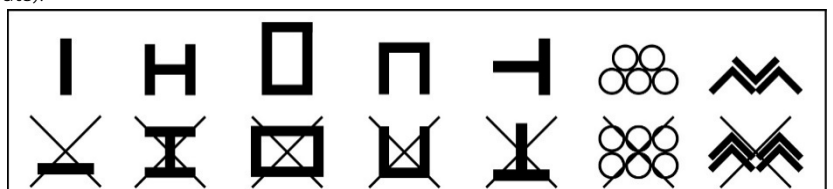

6.7  OPERATING INCIDENTS

**Saw blade jamming in the workpiece**

**Cut the power supply to the machine before performing this operation.**





















**Gloves must be worn**

1. Immediately press the emergency stop button.
2. Carefully open the vise.
3. Carefully raise the saw blade head.
4. Carefully remove the workpiece.
5. Check that the saw blade is not damaged.



**Replace the saw blade if it is damaged (e.g., broken teeth).**

Fault	Remedy
Premature wear:	 Reduce speed.
	 Use a lubricant suitable for the material being cut.
	 Spray the cut with excess water.
	 Check that the saw blade is mounted in the correct direction.
Vibrations of the saw blade during cutting:	 Increase or decrease the speed of the saw blade.
	 Use a finer pitch.
	 Hold the workpiece more firmly.
Tooth breakage:	 Use a finer pitch (for thin thicknesses) or increase the pitch in other cases.
	 Hold the workpiece more firmly.
	 Reduce the feed rate.
Insufficient surface finish:	 Increase the cutting speed.
	 Use a finer pitch.
	 Lubricate the cut.
Convex or concave faces obtained:	 Reduce the feed rate.
	 Use a larger saw cutter pitch.
Chip jamming in the tooth:	 Use a larger pitch.
	 Reduce the depth of cut of the saw blade.
	 Increase the cutting speed.
	 Lubricate the cut.
Insufficient sawing speed:	 Increase the cutting speed.
	 Use a larger pitch.
	 Increase the pressure.
	 Lubricate the cut.

 6.8  TAKING THE MACHINE OUT OF SERVICE

If the chainsaw is not going to be used for an extended period of time, it is recommended that you proceed as follows:

1. Unplug the power supply unit
2. Loosen the saw blade
3. Release the return spring
4. Empty the coolant reservoir
5. Carefully clean and lubricate the machine
6. Cover the machine if necessary

## 7 MAINTENANCE



**Before performing any maintenance or servicing, disconnect the machine.**

**Wear gloves and protective eyewear, and use a clean, dry cloth, brush, long-handled brush, hook, magnetic collector, or vacuum cleaner for all cleaning operations (especially when removing chips, which may be sharp and hot).**



**Do not use a blow gun to remove chips.**

**Do not use solvents or aggressive detergents for cleaning.**

**Do not immerse the machine in water or wash it with a water jet.**



**Chips are often very sharp and hot. Do not touch them with your bare hands.**

To maintain the efficiency of the machine and its components, it is necessary to perform maintenance.

Below are the most important maintenance tasks, which can be classified according to their frequency as daily, weekly, monthly, semi-annual, and annual tasks.

Failure to perform the prescribed tasks will result in premature wear and tear and reduce the performance of the machine.

 7.1  DAILY MAINTENANCE

- Clean the machine as normal to remove any chips that have accumulated.
- Clean the cutting fluid outlet to prevent excess fluid from accumulating.
- Check and refill the cutting fluid reservoir.
- Check that the saw blade is not worn and/or broken.
- Raise the head completely and allow the saw blade to hang slightly to avoid unnecessary stress.
- Check that the protective covers, safety devices, and stop mechanisms are working properly.

 7.2  WEEKLY MAINTENANCE

- Drain the cutting fluid.
- Thoroughly clean the machine, removing any chips from the cutting fluid reservoir.
- Remove the pump from the housing and clean the suction filter and the cutting fluid suction area.

 7.3  MONTHLY MAINTENANCE

- Check that the screws on the motor, pump, and protective casings are tight.
- Check and replace the power cable if necessary.

 7.4  SIX-MONTHLY MAINTENANCE

- Test the continuity of the equipotential protection circuit.

 7.5  ANNUAL MAINTENANCE

- Drain the motor reducer.
- Use type 90 gearbox oil (capacity 0.3 liters).

## 7.6 SPECIAL MAINTENANCE

### Gearbox:

The gearbox oil must be changed periodically. The first oil change is required after 6 months, then once a year.

The oil change must be carried out as follows:

1. Disconnect the machine from the power supply.
2. Lower the head.
3. Unscrew the oil drain plug (A) and drain the oil into a container.
4. When all the oil has been drained, replace the plug (A).
5. Replace the head.
6. Pour oil into the opening of the lowering arm, approximately 0.3 liters.
7. The oil level is located next to it (B).

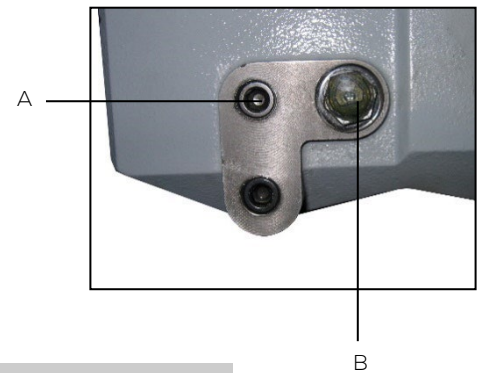

## 8 CONSUMABLES

saw blades

### Available range:

	Ø x Thickness x Bore (mm)	Teeth (mm)	Number of teeth	Reference
PTMF315S	315 x 2,5 x 32	4 pitch	240	PPA402431504
	315 x 2,5 x 32	6 pitch	160	PPA402431506
	315 x 2,5 x 32	8 pitch	120	PPA402431508

## 9 EXPLODED VIEW

## EXPLODED VIEW OF BASE AND HEAD PTMFS315S (VIEW 01)

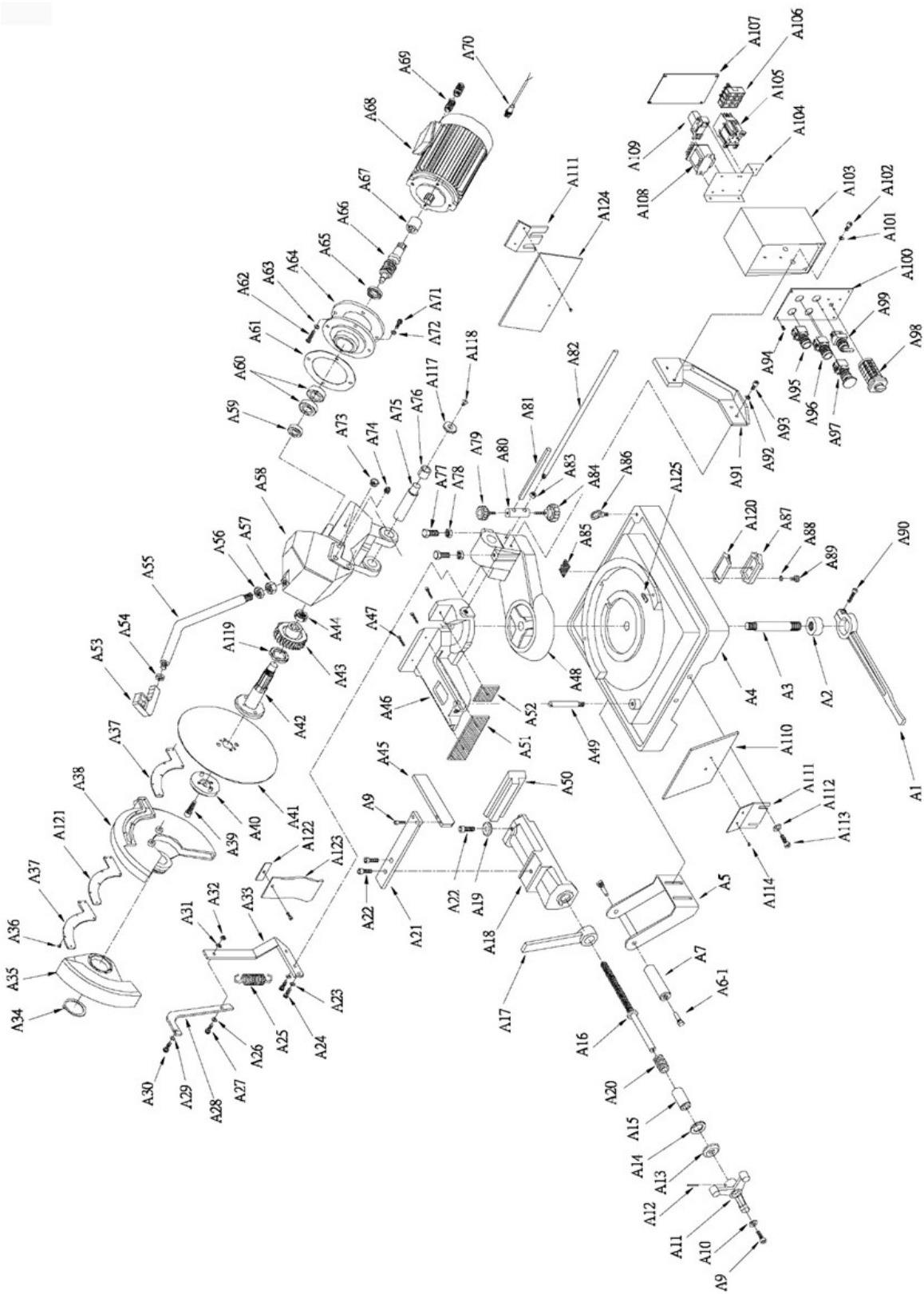

## PARTS LIST EXPLODED VIEW BASE AND HEAD PTMFS315S (VIEW 01)

Reference	Description	Quantity
A01	Lever	1
A02	Bearing	1
A03	Axle	1
A04	Base	1
A05	Support	1
A6-1	Axis	2
A07	Roller	1
A08	Circlip S-12	2
A09	M8x20 screw	1
A10	M8 washer	1
A11	Crank	1
A12	Pin	1
A13	Bearing	1
A14	Washer	1
A15	Bearing	1
A16	Screw on vise end	1
A17	Lever	1
A18	Vise	1
A19	Washer	1
A20	Spring	1
A21	Support	1
A22	M12x25 screw	2
A23	M12 washer	2
A24	M8x20 screw	2
A25	Return spring	1
A26	M8 washer	1
A27	M8x20 screw	1
A28	Tie rod	1
A29	M6 washer	1
A30	M6x12 screw	1
A31	M6 washer	1
A32	M8 nut	1
A33	Tie rod	1
A34	Circlip	
A35	Protector	1
A36	M5x10 screw	7
A37	Plate	
A38	Protector	1
A39	M12Lx35 countersunk screw	1
A40	Saw blade flange	1
A41	Saw cutter	1

Reference	Description	Quantity
A42	Saw blade shaft	1
A43	Bronze pinion	1
A44	Nut	1
A45	Flange	1
A46	Counter clamp	1
A47	M5x25 screw	3
A48	Flange	1
A49	Support	1
A50	Jaw	1
A51	Jaw	1
A52	Jaw	1
A53	Handle with switch	1
A54	M10 nut	1
A55	Arm	1
A56	M20 nut	1
A57	M20 nut	1
A58	Carcass	1
A59	Bearing 6205zz	1
A60	6301zz bearing	1
A61	Seal	1
A62	M8x20 screw	4
A63	M8 washer	4
A64	Flange	1
A65	Gasket	1
A66	Screw with fin	1
A67	Clutch	1
A68	PTMF315S engine	1
A69	Connection	4
A70	Cable	1
A71	M8x20 screw	4
A72	M8 washer	4
A73	½"G oil plug	1
A74	¼"G screw	2
A75	Axle	1
A76	Bearing	1
A77	M12x55 screw	1
A78	M12 nut	1
A79	Knob	1
A80	Flange	1
A81	Stop	1
A82	Bar	1

## NOMENCLATURE EXPLODED VIEW BASE AND HEAD PTMF315S (VIEW 01) (continued)

Reference	Description	Quantity
A83	Nut	1
A84	Knob	1
A85	Grid	1
A86	Ring	3
A87	Flange	1
A88	M8 washer	2
A89	M8x25 screw	2
A90	Screw	1
A91	Bracket	1
A92	M8 washer	2
A93	M8x20 screw	2
A94	M5 screw	4
A95	"STOP" push button	1
A96	"START" push button	1
A97	Latching punch stop	1
A98	Gear shift switch	1
A99	"ON/OFF" switch for cutting fluid pump	1
A100	Front panel	1
A101	M8 washer	2
A102	M8x20 screw	2
A103	Control box	1
A104	Support	1
A105	Contactor	1
A106	Fuse holder	1
A107	Cover	1
A108	Transformer	1
A109	Relay	1
A110	Plate	1
A111	Support	2
A112	M8 washer	2
A113	M8x16 screw	2
A114	M5 screw	2
A117	Cover	2
A118	Screw	2
A119	Washer	1
A120	Gasket	1
A121	Seal	1
A122	Plate	1
A123	Cover	1
A124	Plate	1

## EXPLODED VIEW OF PTMF315S BASE (VIEW 02)

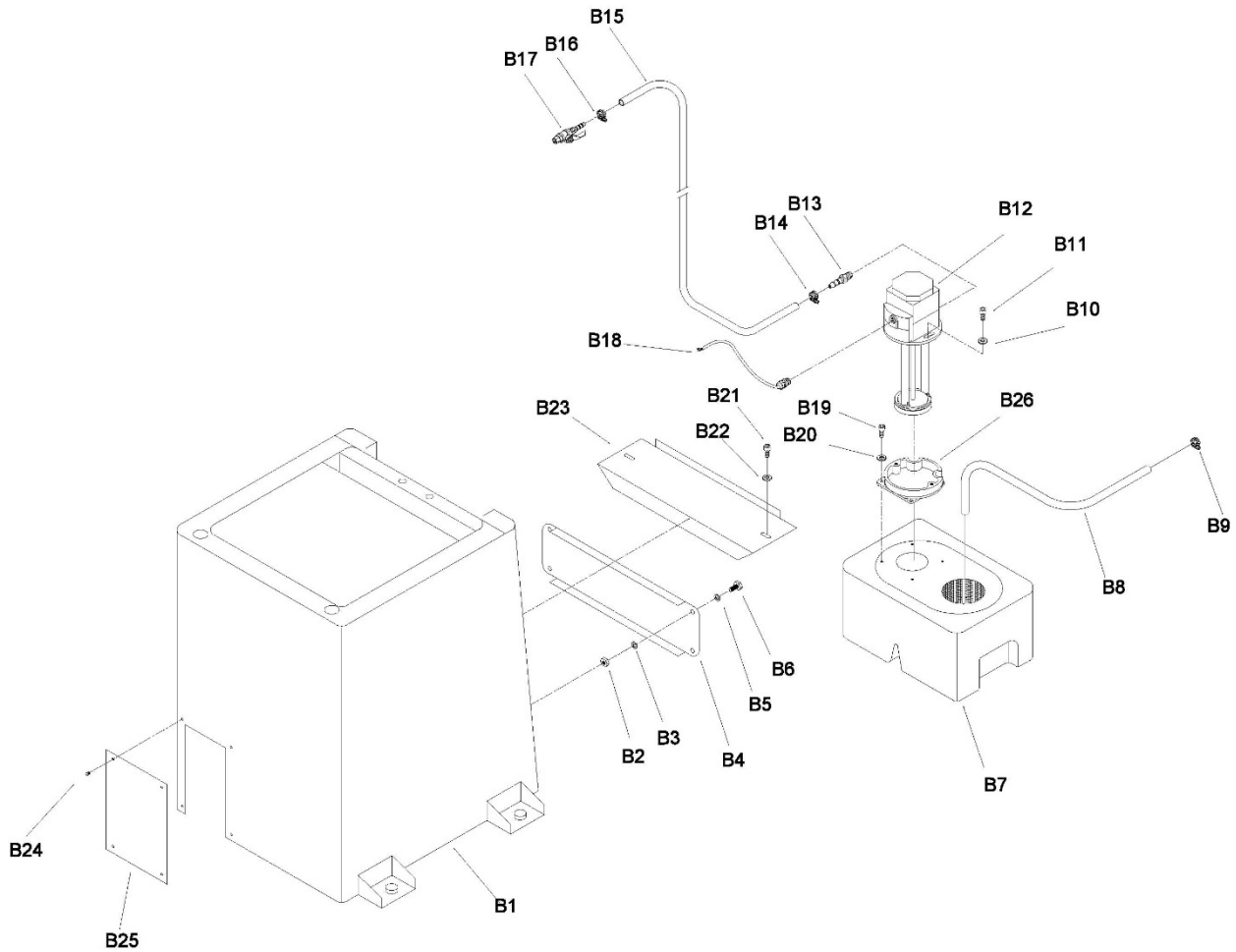

## EXPLODED VIEW PART LIST PTMF315S BASE (VIEW 02)

Reference	Description	Quantity
B01	Base	1
B02	M6 nut	4
B03	M6 washer	4
B04	Plate	1
B05	M6 washer	4
B06	M6x15 screw	4
B07	Tank	1
B08	Tube	1
B09	Clamp	1
B10	M6 washer	2
B11	M6x16 screw	2
B12	Pump motor	1
B13	Fitting	1
B14	Clamp	1
B15	Tube	1
B16	Clamp	1
B17	Valve	1
B18	Cable	1
B19	M6x15 screw	4
B20	M6 washer	4
B21	M6x15 screw	2
B22	M6 washer	2
B23	Plate	1
B24	M5x6 screw	4
B25	Cover	1
B26	Pump motor bracket	1

## 10 ELECTRICAL DIAGRAM

## PTMFS315S ELECTRICAL DIAGRAM

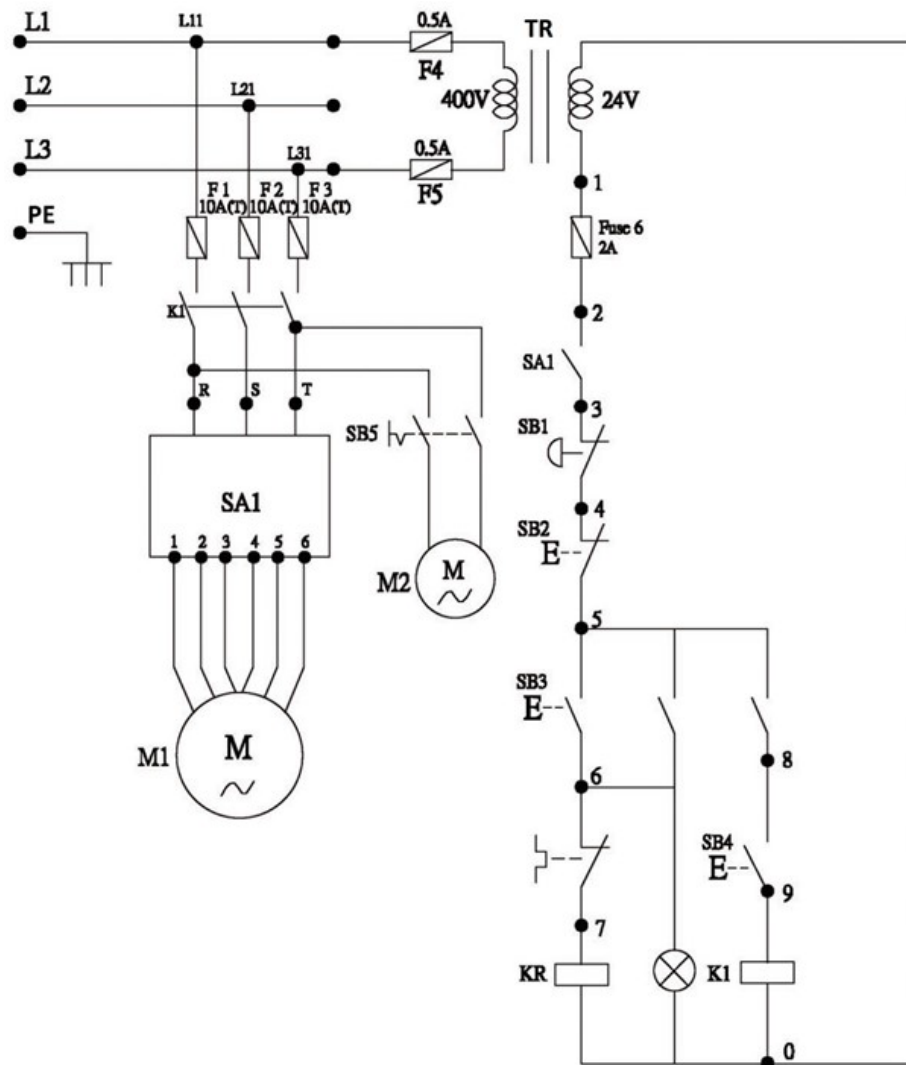

## NOMENCLATURE ELECTRICAL DIAGRAM PTMF315S

Reference	Designation	Quantity
F1	10A(T) fuse	1
F2	10A fuse (T)	1
F3	10A fuse (T)	1
F4	0.5A fuse	1
F5	0.5A fuse	1
F6	2A fuse	1
K1	Contactor	1
KR	Relay	1
TR	400V/24V transformer	1
M1	Motor	1
M2	Cutting fluid pump	1
SA1	Speed switch	1
SB1	Locking punch stop	1
SB2	"STOP" push button	1
SB3	"START" push button	1
SB4	"START/STOP" switch on the lowering arm	1
SB5	"ON/OFF" switch for cutting fluid pump	1
PE	Grounding	1

## 11 NOISE LEVEL

The data relating to the noise level emitted by this machine during operation will depend on the type of material being ground and the type of grinding wheel. For this reason, the measurement data is relative.

The risk of hearing damage to the operator depends on the length of exposure to noise.

The operator must wear ear defenders or other appropriate personal protective equipment when the sound power exceeds 85 dB(A) in the workplace.

- Sound pressure level (1 m at no load):  
**LpA = 74.4 dB(A)**
- Sound power level (1 m at no load):  
**LwA = 79.4 dB(A)**

The sound power calculation was performed taking into account factors such as: reverberation at the test site, ground noise absorption, and other factors that may interfere with the measurements. This estimate allows us to state that the degree of error in the values obtained would be around 3 dB(A).

The values given are emission levels and not necessarily levels that allow for safe working. Although there are correlations between emission levels and exposure levels, these cannot be used reliably to determine whether additional precautions are necessary. Parameters that influence actual exposure levels include workshop characteristics, other sources of noise, etc., i.e., the number of machines and neighboring manufacturing processes. In addition, permissible exposure levels may vary from country to country. However, this information allows the machine user to make a better risk assessment.



## 12 VIBRATION LEVEL

The vibration data transmitted by this machine during operation will depend on the type of material used and the type of disc. For this reason, the measurement data is relative.

Exposure to vibrations can have serious consequences for workers' health. A person exposed to high-amplitude vibrations on a daily basis may develop neurological and joint disorders in the long term. These values must be taken into account when assessing the level of exposure.

Regular and frequent exposure to a highly vibrating work disc exposes workers' hands and arms to chronic disorders known as "vibration syndrome."

- Average hand/arm vibration level:  
**A(8) = 4.45 m/s<sup>2</sup>**

The exposure level assessment is based on the calculation of the daily exposure value A(8), normalized to a reference period of 8 hours.

Whenever an employee is exposed to A(8) vibrations exceeding the daily exposure action level set at 2.5 m/s<sup>2</sup>, the employer must assess the risks of the task assigned to the employee and implement control measures.

Exposure values for vibrations transmitted to the hand-arm system:

- Daily exposure limit value:  
**A(8) = 5 m/s<sup>2</sup>**
- Daily exposure value triggering action:  
**A(8) = 2.5 m/s<sup>2</sup>**

## 13 ENVIRONMENTAL PROTECTION

Your machine contains many recyclable materials.  
This logo indicates that used machines must not be mixed with other waste.

This will ensure that the machines are recycled under the best conditions, in accordance with European Directive 2012/19/EU on waste electrical and electronic equipment.

Contact your local council or dealer to find out where your nearest collection points for used machines are located.

Thank you for your cooperation in protecting the environment.



## 14 WARRANTY

If the machine is covered by warranty, it must be serviced exclusively by an authorized after-sales service center.

The machine warranty is valid for 2 years from the date of purchase by the user.

This product benefits from an additional 2-year warranty extension, provided that the user registers the product on the PEUGEOT OUTILS PROFESSIONNELS website ([www.peugeot-outils-pro.com](http://www.peugeot-outils-pro.com)) within 30 days of the date of purchase. This warranty extension is subject to the same conditions as the initial warranty.

Accessories and consumables are not covered by the warranty.

It is important to keep the invoice, which serves as the warranty certificate.

The warranty is limited to the repair or replacement of defective parts free of charge, after evaluation by the manufacturer.

For any requests for information or spare parts relating to the machine, it is essential to provide the exact information shown on the nameplate.

The warranty does not cover damage caused by the user or by a repairer not approved by Tivoly.

Link to the General Warranty Terms and Conditions:



# CE AL DECLARATION OF CONFORMITY "ORIGINAL"

The undersigned (Manufacturer/Importer):

**TIVOLY**

**266 ROUTE PORTES DE TARENTEISE 73790 TOURS-EN-SAVOIE**

Declares that the following new machine:

- Designation: COLD SAW MACHINE WITH SAW BLADE
- Brand: PEUGEOT PROFESSIONAL TOOLS
- Model: PTMFS315S
- Reference: PPM00200003
- Serial number:

Complies with applicable harmonized legislation:

- **Machinery Directive 2006/42/EC (until January 19, 2027)**
- **EU Regulation 2023/1230 (from January 20, 2027)**

Complies with the essential safety requirements applicable to it:

- **Low Voltage Directive 2014/35/EU**
- **Electromagnetic Compatibility Directive 2014/30/EU**
- **WEEE Directive 2012/19/EU**
- **RoHS-2 Directive 2011/65/EU**
- **REACH 1907/2006**
- **Noise Directive 2003/10/EC**
- **Vibration Directive 2002/44/EC**

Done at TOURS-EN-SAVOIE  
On

Stéphane Le Mounier  
Managing Director



Person authorized to compile the technical file:

- Mr. LE MOUNIER – TIVOLY – 266 ROUTE PORTES DE TARENTEISE 73790 TOURS-EN-SAVOIE

	TIVOLY: Registered office: 266 ROUTE PORTES DE TARENTEISE 73790 TOURS-EN-SAVOIE <a href="http://www.peugeot-outils-pro.com">www.peugeot-outils-pro.com</a>	USER SERVICE Tel: +33(0)4 79 89 59 00
	In its ongoing efforts to improve the quality of its products, TIVOLY reserves the right to modify their characteristics. The information, photos, exploded views, and diagrams contained in this document are not contractual.	Edition april 2026 Manual PTMFS315S