



Get a free 2-year warranty



DE / FR / PT / SP

DRY CUT METAL SAW WITH CARBIDE BLADE PTMC355

IN GOOD HANDS

TRANSLATION OF ORIGINAL INSTRUCTION MANUAL





WHO ARE WE?

Peugeot Professional Tools was born out of several obvious considerations.

The first was to combine the know-how of **Peugeot**, which has mastered the art of cutting since 1810, with the expertise of **Tivoly**, a metalworker since 1917, in order to create a wide range of machines and tools for construction and maintenance professionals.

It was also a natural step to want to serve craftsmen and small businesses driven by strong family and heritage values.

For these professionals, **Peugeot Outils Professionnels** offers machines and tools designed specifically for their needs. **These tools are reliable, durable, and can be repaired in France** and in countries under distribution agreements by local industrial and family partners.

Trustworthy equipment with a longer warranty, logistics, and

French after-sales service. The assurance of dealing with the people who assembled these tools and know every part that goes into them inside out.

From exceptional projects to everyday work, these tools are designed to withstand the most demanding conditions and stand the test of time.

Peugeot Professional Tools was born out of one obvious fact: that our tools are in good hands. The hands of those who work behind the scenes and give their all to satisfy their customers.

Since 1810, many things have changed, but the hands have remained the same. The hands of enthusiasts, craftsmen, dedicated technicians and installers, workers who are proud of themselves and their achievements.

Peugeot Professional Tools: tools in good hands.

THANK YOU FOR YOUR PURCHASE.

We are delighted that you have chosen Peugeot Professional Tools. Every detail has been designed to offer you an exceptional experience, and we hope you enjoy using it as much as we enjoyed creating it for you.

Your trust is essential to us, and we are delighted to accompany you every step of the way in your experience with the Peugeot Professional Tools brand.

Your purchase comes with a 2-year warranty, extendable to an additional 2 years.

















To benefit from this, register at www.peugeot-outils-pro.com

If you have any questions or need assistance, our team is available to provide you with the best possible service.

To contact our after-sales service, visit www.peugeot-outils-pro.com, call [+33\(0\)4.79.89.59.00](tel:+330479895900), or email service@peugeot-outils-pro.com.

Thank you for choosing Peugeot Professional Tools. Your satisfaction is our priority.

CONTENTS

1	INTRODUCTION	4
2	PICTOGRAMS	4
2.1	MACHINE SAFETY PICTOGRAMS	4
2.2	PICTOGRAMS USED IN THIS INSTRUCTION MANUAL	4
3	SAFETY	5
3.1	GENERAL SAFETY REQUIREMENTS.....	5
3.2	SPECIAL SAFETY REQUIREMENTS.....	6
3.3	OPERATOR PROTECTION	6
4	DESCRIPTION AND OPERATION	7
4.1	INTENDED USE OF THE MACHINE.....	7
4.2	CHARACTERISTICS	7
4.3	MACHINE DESCRIPTION.....	7
5	INSTALLATION	8
5.1	 PACKAGING.....	8
5.2	 HANDLING AND TRANSPORT	8
5.3	 INSTALLATION OF THE MACHINE	8
5.4	 ELECTRICAL CONNECTION.....	9
5.5	 INITIAL TEST AND INSPECTION BEFORE FIRST USE.....	9
6	USE	10
6.1	 ADJUSTMENTS.....	10
6.2	 BLADE ASSEMBLY/DISASSEMBLY	12
6.3	 CUTTING PROCEDURE	13
6.4	 OPERATING INCIDENTS.....	14
6.5	 FAULT TABLE	14
7	MAINTENANCE	15
7.1	 DAILY MAINTENANCE.....	15
7.2	 WEEKLY MAINTENANCE	15
7.3	 MONTHLY MAINTENANCE	15
7.4	 CLEANING THE CHIP COLLECTION BIN.....	15
7.5	 CARBON FILTERS.....	16
7.6	 TAKING THE MACHINE OUT OF SERVICE	16
8	CONSUMABLES	16
9	EXPLODED VIEW	17
10	ELECTRICAL DIAGRAM	21
11	SOUND LEVEL	22
12	VIBRATION LEVEL	22
13	ENVIRONMENTAL PROTECTION	23
14	WARRANTY	23
15	DECLARATION OF CONFORMITY	24

1 INTRODUCTION



**For safety reasons, read these instructions carefully before using this machine.
Failure to follow the instructions will result in damage to persons and/or the machine.**

This instruction manual is intended for the operator, adjuster, and maintenance personnel.

This instruction manual is an important part of your equipment. It provides rules and guidelines that will help you use this machine safely and efficiently. You must familiarize yourself with the functions and operation by reading this instruction manual carefully. For your safety, it is particularly important that you read and observe all recommendations on the machine and in this instruction manual.

These recommendations must be strictly followed at all times when using and maintaining the machine. Failure to follow the safety guidelines and warnings in the instruction manual and on the machine and/or use other than that recommended in the instruction manual may result in machine failure and/or injury.

Please keep this instruction manual with the machine or in a place that is easily accessible at all times for future reference. Ensure that anyone involved in the use of this machine can consult it

periodically. If the instruction manual is lost or damaged, please contact us or your dealer to obtain a new copy.

Always use PEUGEOT OUTILS PROFESSIONNELS components and parts. Replacing components or parts other than PEUGEOT OUTILS PROFESSIONNELS may cause damage to the machine and endanger the operator.

This manual describes the safety instructions to be followed by the user. It is the responsibility of the employer or user, in accordance with Article L.4122-1 of the Labor Code, to take care of their health and safety and that of other persons affected by their actions or omissions, in accordance, in particular, with the instructions given to them.

The employer must carry out an assessment of the specific risks associated with their activity, must train workers in the use of the machine and in the prevention of these risks, and must appropriately inform workers responsible for the use or maintenance of work equipment of the instructions or guidelines concerning them.

2 PICTOGRAMS

2.1 MACHINE SAFETY PICTOGRAMS

Meaning of the safety pictograms affixed to the machine (keep them clean and replace them when they are illegible or detached):



Wearing protective eyewear is mandatory



Hearing protection must be worn



Safety shoes must be worn



Gloves must be worn



Respiratory mask must be worn



Do not wear loose clothing, wide sleeves, jewelry, bracelets, watches, wedding rings, etc.
Wear hair nets for long hair



Read the instructions carefully



Direction of blade rotation

2.2 PICTOGRAMS IN THIS INSTRUCTION MANUAL



Direct danger to persons and damage to the machine.



Possible damage to the machine or its surroundings.



Wear protective goggles and gloves when changing the band and cleaning.



Minimum number of personnel required for certain operations.



Note.



If necessary, wear respiratory protection to reduce the risk of inhaling hazardous dust.



Technical skill level: operator, user.



Technical skill level: adjuster, maintenance.



Technical skill level: maintenance technician.



Electrical work must be carried out by qualified personnel authorized to perform low-voltage electrical work.

3 SAFETY

3.1 GENERAL SAFETY REQUIREMENTS



To reduce the risk of fire, electric shock, mechanical shock, and personal injury when using power tools, follow basic safety precautions.

This instruction manual only takes into account reasonably foreseeable behavior.

Our machines are designed and manufactured with operator safety in mind.

The machine must not be used by young workers under the age of eighteen.

We accept no liability for any damage caused by inexperience, incorrect use of the machine and/or damage to it and/or failure to comply with the instructions and safety rules contained in this instruction manual.

As a general rule, accidents always occur as a result of misuse or failure to read the instruction manual.

We remind you that any modification to the machine will result in our withdrawal of liability.

Check the presence, condition, and operation of all guards before starting work.

Ensure that moving parts are working properly, that there are no damaged components, and that the machine is in perfect working order during start-up.

Only competent and authorized personnel are permitted to repair or replace damaged parts.

Keep the work area clean and tidy.

Ensure that the entire work area is visible from the work position. Cluttered work areas and workbenches are a potential source of injury.

Do not use the machine outdoors when weather and environmental conditions do not permit it or in very humid locations. Reserve it for indoor use, in a dry, well-ventilated area free from flammable liquids or gases.

Position the machine in a sufficiently lit work area.

Do not allow unauthorized persons, especially children and animals, to touch the tools or electrical cables, and keep them away from the work area.

Turn off the machine when you have finished using it. Always disconnect the power supply.

Never leave the machine unattended while it is running. Only leave the machine when it has come to a complete stop.



Do not force the disc; it will perform better and be safer at the speed for which it is designed.

Do not use discs for work for which they are not intended.



Do not damage the power cord.

Never pull on the power cord to remove it from the electrical outlet.

Keep the power cord away from heat sources, greasy areas, and/or sharp edges.

Protect the power cord from moisture and any potential damage. Check the power cord periodically. If damaged, have it repaired by an authorized repairer.

Defective switches must be replaced by a qualified person or an authorized repairer.

Do not use the machine if the switch does not control the stop or start functions.



Do not overestimate your strength.

Always maintain a stable position and good balance.

Be aware of what you are doing and use common sense.

Do not use the machine when tired.

Always use both hands to operate this machine.

The use of any accessories other than those described in the instruction manual may present a risk of injury to persons.

The user is responsible for their machine and must ensure that:

- The chainsaw is used by people who have read the instructions and are authorized to do so.
- Safety rules are followed.
- Users have been informed of the safety rules.
- Users have read and understood the instruction manual.
- Responsibilities for maintenance and any repairs have been assigned and observed.
- Defects or malfunctions were immediately reported to an authorized repairer or your dealer.
- The chainsaw must be used in the areas of application described in this manual.
- Any use other than that specified in this instruction manual may constitute a hazard.
- Mechanical and/or electrical guards must not be removed or bypassed.
- No modifications and/or conversions must be made.

PEUGEOT OUTILS PROFESSIONNELS declines all responsibility for damage caused to persons, animals, or objects as a result of failure to comply with the instructions and safety rules contained in this instruction manual.

3.2 SPECIAL SAFETY REQUIREMENTS



Special safety requirements for band saws.

Before use, the machine must be correctly assembled.
 Do not plug in if the saw is not placed on a flat, stable surface that is free of obstacles and well lit.
 Check that the blade is securely tightened.
 Do not use a damaged or deformed blade to avoid kickback.
 Check that the blade guards are working properly.
 Never block the blade guards.
 Do not operate the blade when the guards or blade guard are removed.
 Ensure that no wrenches are left on the chainsaw before starting it.
 Check that the adjustable rear jaw locking handle is tightened securely before making a cut.
 For all 45° right and 45° left cuts, install the prismatic jaw on the adjustable rear vise jaw to allow the profile to be offset.
 Use a clamp for cuts at 20° to the right.
 Check the condition and attachment of the protective screen.
 Do not use this machine to cut building materials, wood, PVC, or derivatives.
 Occasional cutting of non-ferrous metals (aluminum, stainless steel).
 For full cuts, reduce the stated capacities by 40%.
 In all cases, remain focused on the task at hand.
 For all operations involving a risk of cutting, burning, pinching, snagging, entanglement, or crushing, in particular when loading and unloading workpieces, changing blades, or handling the workpiece or vise, stop the machine and wear protective gloves.
 Do not hit the construction chainsaw against the workpiece to be cut, but apply pressure gradually.
 Do not start cutting with the blade against the workpiece.
 Do not touch the moving blade.
 Do not use cutting fluid.
 Always wear protective eyewear.
 Keep your hands away from the cutting areas when the machine is in operation.
 Always hold the chainsaw with both hands while wearing protective gloves.
 Never hold workpieces by hand; clamp them securely in a vise.
 Use prismatic jaws or a clamp depending on the cut.
 Wear hearing protection.
 Ensure that the switch is in the "off" position before plugging the saw into a power outlet.

Wear respiratory protection to reduce the risk of inhaling hazardous dust.
 When you have finished cutting, release the switch and return the head to its starting position (rest, upwards).
 When the machine is turned off, the blade continues to rotate for a few seconds before coming to a complete stop.
 The blade can become very hot during operation. Wait for the blade to cool before replacing it.
 Before performing any positioning or removal of material waste, disconnect the power supply.
 Do not add additional accessories for operations for which they are not designed.
 Using an inappropriate accessory can lead to accidents.
 Always keep the blade clean.
 Do not clean the blade while it is moving.
 When cleaning, wear protective goggles and gloves, and use a brush and a clean, dry cloth.
 Do not immerse the machine in water or wash it with a pressurized water jet, as this may cause water to enter the electrical components.
 Do not use solvents or aggressive detergents.
 Always keep the chainsaw's work platform clean and uncluttered.
 Keep the engine cover clean and uncovered to ensure the machine functions properly.
 Do not use the machine continuously for more than 30 minutes.
 Stop the machine and check that the moving parts are locked when moving the chainsaw.
 Store the machine in a dry place out of the reach of children.



Accidents are usually the result of:

- Lack of accessories that allow the workpiece to be held securely.
- Disorder: accessories, if any, are not stored away and the operator cannot find them, so does without them.
- Inappropriate or dangerous operating procedures.
- Insufficient training, learning, and/or experience of operators in the use of the machine.
- Absence of protective covers during machine use.
- Ill-fitting clothing, lack of safety glasses for certain tasks.

3.3 OPERATOR PROTECTION



For operator safety, ensure that non-working parts are always covered by a protective guard.

This machine is designed for a single operator.
 The operator must wear appropriate personal protective equipment:

- Safety glasses.
- Hearing protection.
- Safety shoes.
- Protective gloves.
- Respiratory protection.



The operator must wear close-fitting clothing and, if necessary, hair coverings for long hair.

The operator must not wear, for example:

- Loose-fitting clothing with wide sleeves.
- Bracelets, watches, wedding rings, jewelry.
- Any other objects that could become caught in the moving parts of the machine.



4 DESCRIPTION AND OPERATION

4.1 INTENDED USE OF THE MACHINE

The PTMC355 construction site cut-off saw is a machine designed and manufactured solely for occasional use in dry cutting ferrous metals (steel, iron, cast iron), profiles or solids, using a carbide blade. For cutting solid metals, reduce the stated capacities by 40%.

The machine can also be used for occasional cutting of non-ferrous metals (aluminum, stainless steel).

Under proper conditions of use and maintenance, safe operation and work are guaranteed for several years. To do this, explore the machine's various functions.



Do not use this machine to cut building materials (concrete, cinder blocks, paving stones, stone, etc.), wood, PVC, or derivatives.

4.2 FEATURES

- Occasional dry cutting of ferrous metals on construction sites
- Carbide blade cut-off saw
- Fast, burr-free cutting of metal profiles without heating the material or using water spray
- Soft start motor
- Quick-release vise
- Vise jaws adjustable from 0° to 45° to the left and right
- Depth stop
- Rear jaw adjustable by 80 mm
- 7 cutting angle positions: -15°, -30°, -45°, 0°, +15°, +30°, and +45°
- Lockable switch and anti-interference filter
- Manual reset thermal circuit breaker
- Protective screen and chip collector
- Head locking chain for transport
- Supplied with carbide-tipped blade \varnothing 355 x 2.4 x 25.4 mm - 80 teeth (steel), 2.5/6/8 mm hex keys and prismatic jaws

Cutting capacities (mm)	Round	Square	Rectangular (L x H)	Vise opening (mm)	Blade dimensions (mm)	Rotation speed (rpm)	Power supply	Motor power (kW)	Weight (kg)	Dimensions (W x H x D) (mm)
90	130	120	180 x 95	180	355 x 2.4 x 25.4	1300	230 V single-phase	2.2	24	340 x 600 x 630
45°	105	90	100 x 80	120						

4.3 MACHINE DESCRIPTION



5 INSTALLATION

5.1 PACKAGING



A small moisture-proof bag may be included in the packaging. Keep it out of the reach of children and dispose of it.

The construction chainsaw is packaged and supplied with a carbide-tipped blade in a cardboard box for easy handling, transport, and storage.

When unpacking, the chainsaw head is locked in the lower position with a chain for transport purposes. To move the head upwards, simply unhook the chain from the motor housing.

Remove each component of the construction chainsaw, check its overall condition, and then proceed with assembly.

If the product does not appear to be in good condition or if any parts are broken or missing, contact your dealer. Keep the instruction manual for future reference.

5.2 HANDLING AND TRANSPORT

Given the weight (23.5 kg) and dimensions of the machine, handling and installation can be carried out by one person.

To transport the construction site chainsaw, always lock the cutting head in the down position using the transport chain provided for this purpose. A handle makes it easy to carry.

5.3 INSTALLING THE MACHINE

Installation environment:

- Power supply voltage in accordance with the machine's specifications.
- Ambient temperature between +5°C and +35°C.
- Relative humidity not exceeding 90%.
- Sufficient ventilation at the installation site.
- Work area sufficiently lit for safe working: lighting must be 500 LUX.

Consider the location of the machine in the room; it must allow for easy movement and maneuvering. Maintain a minimum distance of 800 mm between the rear of the machine and the wall.

Position the machine on a flat, horizontal surface so that it is as stable and level as possible.

Use machine support frames with sufficient capacity.

To perform machining operations in accordance with ergonomic criteria, the ideal height is one that allows the vise surface to be positioned approximately 90/95 cm from the floor.

Ensure that no one is in the path of debris and sparks caused by cutting.

5.4 ELECTRICAL CONNECTION



Electrical work must be carried out by qualified personnel authorized to perform low-voltage electrical work.



ELECTRICAL PRESENCE

Ensure that the power supply voltage of the installation corresponds to that of the machine.

Connect the power supply using the power cable.

Check that the power outlet of your installation is compatible with the machine's plug.

Use a socket that complies with the "EN 60309-1" standards for the connection.

Check that the electrical installation to which the machine will be connected is properly earthed in accordance with current safety standards.

We remind users that there must always be a magnetothermal protection device upstream of the electrical installation to protect all conductors against short circuits and overloads.

This protection must always be selected based on the electrical characteristics of the machine, as specified on the nameplate:

- Voltage: 230 V single-phase
- Frequency: 50 Hz
- Current: 10 A
- Motor power: 2.2 kW

Electrical connections and extension cords must be protected from splashes and kept on dry surfaces.

Regularly check the condition of the power cord, switch, and cable gland.



Use of the device with a damaged cable is strictly prohibited.



Use a cable reel with a cross-section and length appropriate for the power of the device, and unroll it completely.



Do not remove the plug from the power outlet by pulling on the cord; pull only on the plug.



**Check the direction of rotation of the carbide blade.
The warranty does not cover damage caused by incorrect connection.**

The blade rotation direction pictogram is located on the blade guard, as is the pictogram for the carbide blade mounting direction.

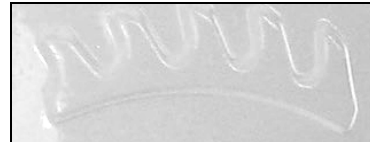

5.5 INITIAL TEST AND INSPECTION BEFORE FIRST USE

- Check that the chainsaw is on a flat, horizontal surface so that it is as stable and level as possible.
- Check that moving parts are working properly and that there are no damaged components.
- Check that the guards are present, intact, and in good working order.
- Check the condition of the blade.
- Check the blade head descent, the protective cover, and the blade covers.
- Check that the machine operates perfectly when empty.

6 USE



Before starting the machine, familiarize yourself with the controls.



Before performing any maintenance or servicing, disconnect the power supply.

 6.1  ADJUSTMENTS

Disconnect the machine from the power supply before performing these operations.

Angle cuts

The chainsaw allows you to make cuts with a cutting angle indexing of 7 positions from 0° to 45° to the left and right:

1. Loosen the locking handle of the adjustable rear jaw (A) by turning it counterclockwise (press with your thumb while pulling upward against the spring tension to loosen the handle).
2. Turn the rear jaw (B) to the desired angle position.
3. Tighten the rear jaw locking handle (A).
4. The front jaw (C) pivots into the intended position and will automatically align with the workpiece.

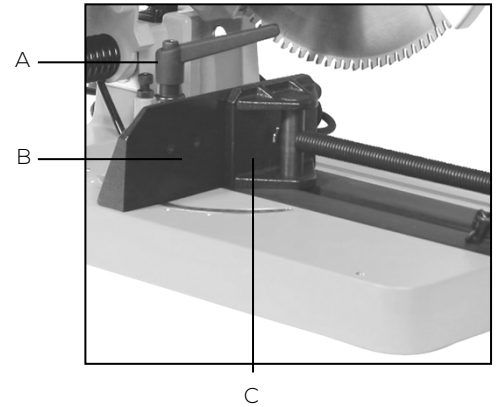

Ensure that the rear jaw locking handle is correctly positioned so as not to interfere with the head descent during cutting.



At 45° to the right, the profile to be cut cannot protrude from the machine on the left side without installing the prismatic jaw on the adjustable rear vise jaw, which allows the profile to be offset.



When cutting at 45° left, the blade is not able to make a complete cut. To make a complete cut at 45° left, install the prismatic jaw on the adjustable rear vise jaw to allow the profile to be offset.

Vise assembly

Quick-release clamp:

1. Place the workpiece against the adjustable rear vise jaw at the desired cutting angle.
2. Flip the release lever to the left to release the vise pin.
3. Slide the front swivel vise jaw toward the workpiece to engage it.
4. Flip the release lever to the right to lock the vise pin.
5. Tighten the vise completely using the crank handle.

Clamping the workpiece



Do not place workpieces to be cut on the vise assembly:

- **During cutting.**
- **When a profile is already inserted in the vise.**

1. Open the vise sufficiently.
 2. Measure the workpiece and mark the cutting line.
 3. Place the workpiece to be cut between the jaws.
 4. Align the workpiece to be cut with the blade and the adjustable rear vise jaw.
 5. Clamp the workpiece as described above.
- To ensure precise cuts, optimum performance, and increased blade life, the figures opposite show the recommended positioning of profiles in the vise (for straight 90° cuts).
 - Always cut on the thinnest side of the workpiece.

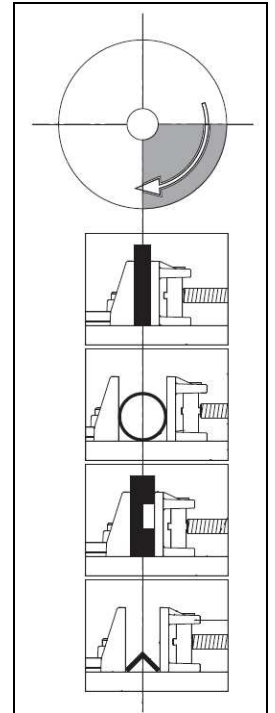

Blade downward stroke

The descent stroke can be adjusted using the depth stop:

1. Loosen the lock nut (A).
2. Tighten or loosen the stop screw (B) as needed.
3. Then retighten the lock nut (A).



The stop screw (B) must not be tightened too far, as this will cause the blade to cut into the chip tray. Ensure that the stop screw is always at the correct height before starting the machine.

6.2  BLADE INSTALLATION/REMOVAL

Disconnect the machine from the power supply before performing this operation.



**Never install a blade that is damaged, warped, bent, cracked, or chipped (risk of kickback).
Install a blade that complies with the machine's recommendations for use.**



Replace the blade when the teeth are worn or broken to avoid additional vibrations, imprecise cuts, and kickback.



Only use blades that comply with the original blade: same diameter, thickness, and bore.



Only use carbide-tipped blades recommended by PEUGEOT OUTILS PROFESSIONNELS with a speed equal to or greater than the speed indicated on the tool's nameplate.



Gloves must be worn.

1. Ensure that the chainsaw head is in the raised position.
2. Unscrew the three screws (A) located on the blade guard.
3. Swivel the guard to the left. If the guard remains stuck without fully releasing the blade, loosen the pressure screw that locks the pivot pin (B) to release the guard.
4. Press the blade lock button (C) and simultaneously turn the blade until the lock engages.
5. Once the blade lock button is engaged, use the hex key supplied with the machine to loosen the screw (D).
6. Remove the screw (D), washer, and outer blade flange.
7. Carefully remove the blade.
8. Ensure that the blade support surfaces are clean and free of foreign particles.
9. Install a new blade on the inner flange.
10. Refit the outer blade flange, washer, and screw (D).
11. Tighten the screw (D) clockwise with the hex key, ensuring that the blade lock button (C) is engaged.
12. Release the blade lock button.
13. Replace the blade guard.
14. Tighten the three screws.
15. Ensure that the blade is not mounted at an angle.

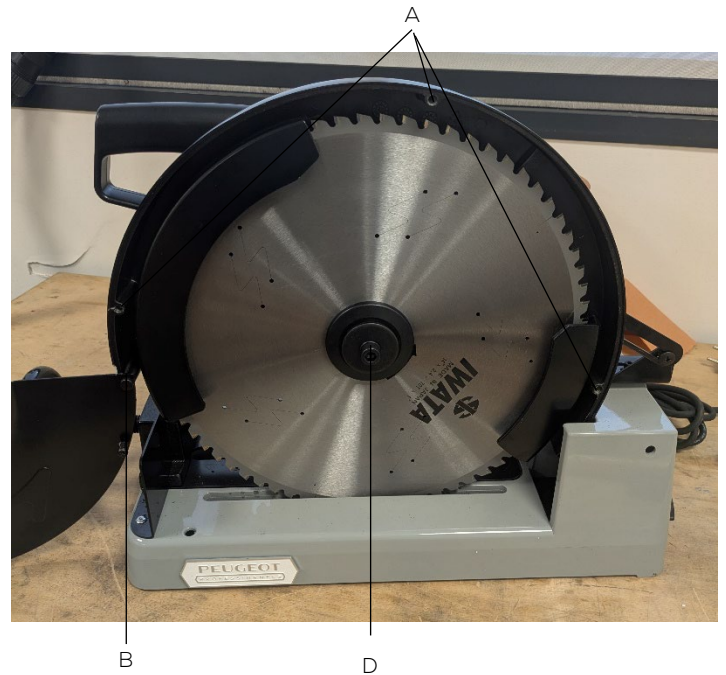

**Do not remove the inner blade flange.
When reassembling the blade, ensure that the clamping flanges and axle bolt are clean. Only use original flanges.**

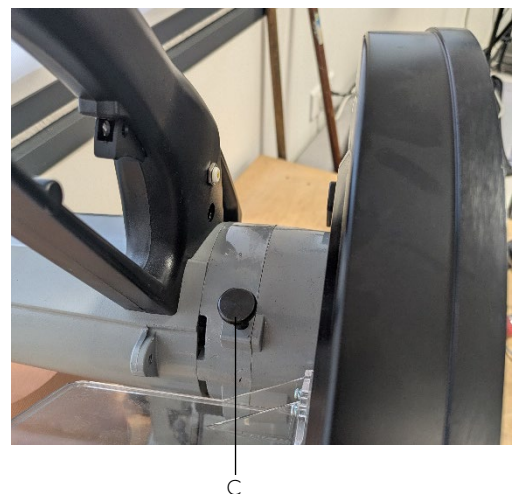

After tightening the blade, always turn the blade backward with the wrench to help release the blade lock button.



Ensure that the blade teeth are facing the correct direction during assembly.

6.3  CUTTING PROCEDURE

Wearing appropriate personal protective equipment is mandatory. When cutting, there is a risk of sparks or hot metal debris being projected.



Keep your hands away from the cutting areas when the machine is in operation. Before positioning the profile or removing cutting waste, stop the machine.



Always use the vise: the parts to be cut must be securely clamped in the vise to prevent any projections.



Never touch the blade lock button during operation.



Before using the machine, ensure that:

- The blade lock button is disengaged.
- The blade tightening wrench has not been left on the axle bolt.
- Both blade guards are in place on the protective cover.
- The rear jaw lock handle is correctly positioned so as not to interfere with the head descent during cutting.



Operating cycle

Cutting instructions:

1. Set the rear jaw to the desired cutting angle.
2. Adjust the depth stop.
3. Open the front jaw sufficiently.
4. Position the material in the vise at the desired length.
5. Secure the material properly.
6. Press the switch (A) to start the motor and allow the blade to reach its maximum speed.
7. Lower the head slowly toward the material to be cut, applying constant and correct pressure, avoiding any sudden contact.
8. If the cut is made with excessive force, the disc will tend to bend and the cut will be uneven.
9. Do not stand in front of the blade, but slightly to the side.



A



Allow the blade to reach its maximum speed before starting to cut. Do not brake or block the blade by applying excessive pressure.



Wait until the blade has come to a complete stop before locking or unlocking a workpiece or changing the cutting angle.

Stopping:

1. Raise the head when the cut is complete.
2. Release the switch (A) and the machine will stop. The blade will continue to rotate for a few seconds before coming to a complete stop.
3. After cutting, return the head to its initial position.
4. Open the vise.
5. Push back the piece to be cut or remove it.



When cutting is complete, release the switch and return the head to its starting position (rest, upwards).

Locking the switch in the "OFF" position

- When the machine is not in use, it is recommended to lock the switch in the "OFF" position using a padlock passed through the hole in the trigger (C).

6.4  OPERATING INCIDENTS

Blade jamming in the workpiece

Disconnect the machine from the power supply before performing this operation.



Gloves must be worn.

1. Release the switch.
2. Unplug the power cord.
3. Carefully open the vise.
4. Carefully raise the blade head.
5. Carefully remove the workpiece.
6. Check that the blade is not damaged.



Replace the blade if it is damaged (e.g., broken teeth).

 6.5  FAULT TABLE

FAULT	SOLUTION
Premature blade wear:	 Apply constant and correct pressure.  Check that the blade is mounted in the correct direction.
Blade vibration during cutting:	 Apply constant and correct pressure.  Replace the blade.  Hold the workpiece more firmly.
Teeth breaking off:	 Replace the blade.  Hold the piece more firmly.  Apply constant and correct pressure.
Insufficient surface condition:	 Apply constant and correct pressure.  Replace the blade.
Convex or concave surfaces obtained:	 Apply constant and correct pressure.  Replace the blade.
Chips stuck in the teeth:	 Replace the blade.  Apply constant and correct pressure.
Insufficient sawing speed:	 Apply constant and correct pressure.  Replace the blade.
Cut not perpendicular:	 Do not force the cut; let the blade do the work.
The motor lacks power:	 Increase the cross-section of the extension cable.  Resolve the drop in power supply voltage.  Do not force the cut; let the blade do the work.
The motor has stopped and will not restart:	 Do not force the cut; let the blade do the work after the thermal protection has been activated.  Increase the cross-section of the extension cable following motor overload.  Resolve the drop in power supply voltage.  Replace the carbon brushes.

7 MAINTENANCE



Disconnect the machine from the power supply before performing these operations. Wear gloves and protective eyewear, and use a brush and a clean, dry cloth for all cleaning operations (especially when removing chips).



Do not use solvents or aggressive detergents. Do not use compressed air to remove machining chips. Do not immerse the machine in water or wash it with a water jet.



Chips are often very sharp and hot. Do not touch them with your bare hands.

To maintain the efficiency of the machine and its components, it is necessary to perform maintenance on the machine. Below are the most important maintenance tasks, which can be classified according to their frequency as daily, weekly, or monthly tasks.

Failure to perform the prescribed tasks will result in premature wear and tear and reduce the performance of the machine.

 7.1  DAILY MAINTENANCE

- Clean the machine as normal to remove any chips and dust that have accumulated.
- Check that the chainsaw blade is not worn and/or the teeth broken.
- Check that the protective covers and switch are working properly.

 7.2  WEEKLY MAINTENANCE

- Thoroughly clean the machine to remove chips in particular.
- Check that the protective guards and controls are working properly, looking for any defects.

 7.3  MONTHLY MAINTENANCE

- Check that the screws on the motor and protective covers are tight.
- Check and replace the power cable if necessary.
- Lubricate the rotating and sliding parts of the vice, the rotating part of the motor shaft, and the head lift shaft (use machine oil). All bearings are lubricated for life.

 7.4  CLEANING THE CHIP COLLECTION TRAY

Chips are often very sharp and hot. Do not touch them with your bare hands.

The construction saw has a chip collection tray located to the right of the base. When the tray is full, the chips must be removed:

1. Unscrew the fastening knob (A).
2. Remove the tray (B) to clean it.
3. Replace it and tighten the fastening knob (A).



7.5 CARBON BRUSHES



Disconnect the machine from the power supply before performing this operation.



Always replace the carbon brushes in pairs.



For a simple check, make sure to replace the carbon brushes correctly as they were originally. Do not swap the carbon brushes after checking them.



Replace the carbon brushes when one brush has worn down to less than 6 mm in length, or when a brush has burned out.

The service life of the carbon brushes varies depending on the motor load and usage. Check the carbon brushes regularly and replace them when they reach their limit of use.

To replace them, the carbon brushes are located on either side of the motor:

1. Unscrew the four screws on the motor cover and remove it.
2. Using pliers, turn the tension spring (A) away and slide the carbon brush (B) out of its holder.
3. Unscrew the screw (C) to disconnect the carbon brush wire from the power supply.
4. Remove the carbon brush.
5. Clean the carbon brush holder.
6. Install a new carbon brush.
7. Re-tighten the power supply screw, reconnecting the carbon brush wire.
8. Replace the tension spring correctly.
9. Replace the motor cover.

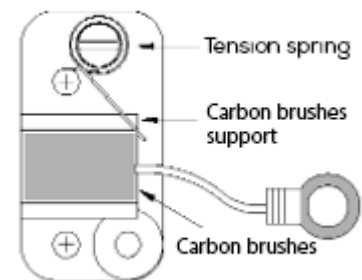
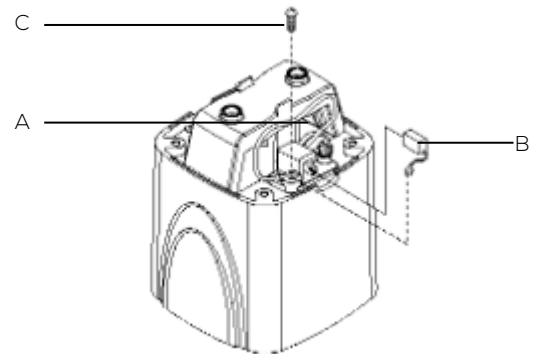

7.6 TAKING THE MACHINE OUT OF SERVICE

If the chainsaw is not going to be used for a prolonged period, we recommend that you proceed as follows:

1. Disconnect the plug from the power supply.
2. Loosen the blade.
3. Clean the machine carefully.
4. Cover the machine if necessary.

8 CONSUMABLES

CARBIDE BLADE

- To ensure fast cutting and long motor life, it is essential to use original PEUGEOT OUTILS PROFESSIONNELS blades.

	Ø x Thickness x Bore (mm)	Number of teeth	Reference
Carbide blade	355 x 2.4 x 25.4	80	PPA4014355080



9 EXPLODED VIEW

EXPLODED VIEW PTMC355 (VIEW 01)

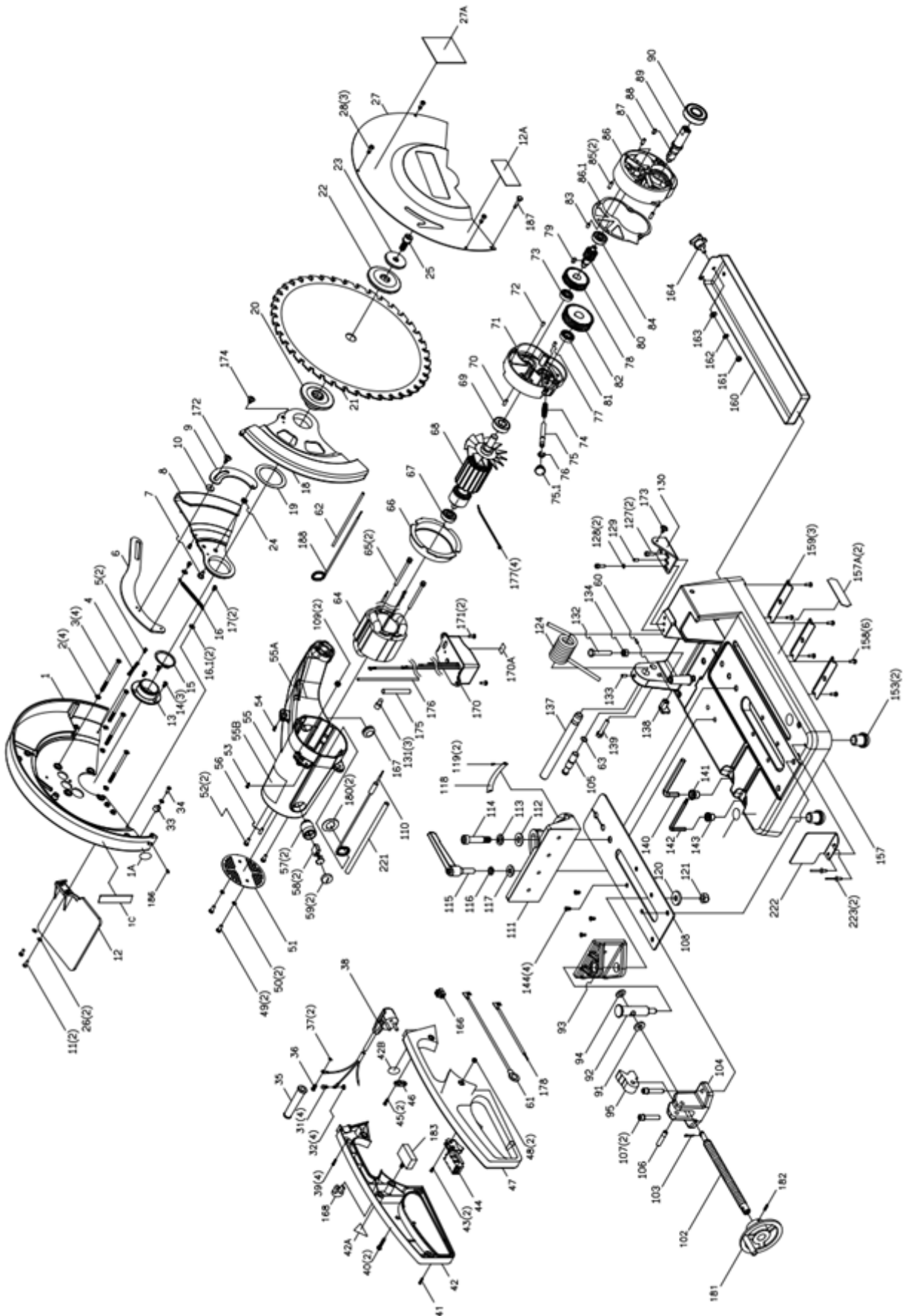

EXPLODED VIEW NOMENCLATURE PTMC355 (VIEW 01)

Ref.	Description	Qty
1	SAFETY COVER #250 Orange RAL 2008	1
001A	WARNING LABEL 20x20mm	1
001C	ARROW STICKER 95x20mm	1
2	MILLED TOOTHED WASHER D5	4
3	SIX-SIDED HOLLOW HEAD SCREW M5X85mm	4
4	SPRING	1
5	M4X8mm ROUND HEAD SCREW	2
6	LEVER	1
7	WEDGE SCREW	1
8	BLADE GUARD #250 Orange RAL 2008	1
9	LEVER	1
10	SPACER	1
11	ROUND HEAD SCREW + WASHER M4X0.7X12mm	2
12	PC PROTECTIVE PLATE	1
012A	WARNING LABEL 90x35mm	1
13	ROLLING SUPPORT	1
14	FLAT HEAD SCREW M4x10mm	3
15	OUTER RETAINING RING S42	1
16	SPRING D5XD0.8X70mm	1
016.1	WASHER D5XD11X0.8t	2
17	LARGE BLADE GUARD #250 Orange RAL 2008	2
18	SPACER D50.6X67X0.15mm	1
19	OUTER RETAINING RING S42	1
20	FLANGE	1
22	FLANGE	1
23	FLAT WASHER M10	1
24	SPACER	1
25	SOC HEXAGONAL SCREW + WASHER	1
26	FLAT WASHER	2
27	14" COVER #250 Orange RAL 2008	1
027A	CUSTOMER PLATE (PEUGEOT)	1
28	Special hexagon screws with S washers	3
32	PAN HEAD SCREW #6X6.8mm	4
33	STOP	1
34	HD FLAT SCREW M4x15mm	1
35	CORD PROTECTION	1
36	PAN HD SCREW M5X0.8X20mm	1
37	EXTERNAL TOOTHED LOCK WASHER D5mm	1
38	POWER CABLE H05RN-F1.0X3CX3M	1
39	M4X16mm SELF-TAPPING SCREW	4
40	PAN SCREW HD + WASHER M5X27mm	2
41	PAN HD SELF-DRILLING SCREW 1/8X5/8"	1
42	LEFT HANDLE	1
042A	ELECTRICAL SAFETY STICKER 15x15mm	1
042B	EARTH SYMBOL 12x12mm	1
43	M4X10mm PAN HD SELF-DRILLING SCREW	2
44	JT-9104A YELLOW SWITCH	1
45	M4X16mm SELF-TAPPING SCREW	2
46	PA6 CORD CLAMP	1
47	RIGHT HANDLE	1
48	M5 HEX NUT	2
49	PAN SCREW HD M5X12mm	2
50	D5 LOCK WASHER	2
51	END COVER	1
52	PAN SCREW M5X12mm	2
53	SELF-DRILLING SCREW M4X16mm	1
54	M4X16mm self-tapping screw	1
55	MOTOR COVER #251 Dark gray RAL 9004	1
055A	TECHNICAL DATA PEUGEOT PTMC355 84x54mm	1
055B	SPECIAL HEXAGONAL KEY 83x38mm	1
56	RUBBER SHAFT D5X13mm	1
57	BRUSH HOLDER	2
58	SET OF BRUSHES 7X17X19/17(105S)	2
59	BRUSH COVER	2
60	ADJUSTING SCREW M4X8mm	1
61	JUMPING WIRE 16X130mm(BLUE)	1
62	INSULATING SHEATH D4.34Xd3.5X0.42tX150mm	1
63	O-RING P-10	1
64	230V FIELD ASSEMBLY	1
65	HEXAGON HEAD SCREW + WASHER M5X70mm	2
66	DEFLECTOR	1
67	BEARING 6200	1

68	INDUCTOR / ROTOR	1
69	BEARING 6202	1
70	RUBBER ROD D5X13mm	1
71	INTERNAL GEAR COVER #251 Dark gray RAL 9004	1
72	RUBBER ROD D5X8mm	1
73	6000Z BALL BEARING	1
74	SPRING D11X1.2X30mm	1
75	LOCKING PIN	1
075.1	KNOB / DIAL	1
76	CIRCLIP (ETW) E7	1
77	RUBBER ROD D5X8mm	1
78	FRONT GEAR	1
79	KEY 5X5X12mm	1
80	GEAR SHAFT M1.5X15t	1
81	BALL BEARING 6001 ZZ C3 RCL -2/P6Z3V3	1
82	REAR GEAR	1
83	RUBBER ROD D5X8mm	1
84	BEARING 6200	1
85	PIN NR5X14.8mm	2
86	OUTER GEAR COVER #251 Dark gray RAL 9004	1
086.1	OIL SEAL	1
87	D5X14mm PIN	1
88	KEY 5X5X12mm	1
89	PIN	1
90	BEARING 6204 ZZ	1
91	FLAT WASHER D10.5X22ODX3T D10.5XD22X3t	1
92	PIN SS41	1
93	VICE JAW	1
94	FLAT WASHER D10.5XD20X1.2t	1
95	THREADED NUT	1
102	SCREW	1
103	PIN 3.2X15mm	1
104	SUPPORT #58	1
105	LOCKING PIN	1
106	8MM PIN D8X38mm	1
107	HEXAGONAL CYLINDRICAL HEAD SCREW + WASHER M8X40mm SCM435	2
108	ADJUSTMENT PART	1
109	M5 HEX NUT	1
110	BRIDGE WIRE 14AWGX240mm	1
111	CLAMP PLATE	1
112	FLAT WASHER D12XD26X2t	1
113	ELASTIC WASHER D12	1
114	SCM435 VISE FASTENING COLUMN	1
115	M10X40mm LOCKING LEVER (ZDC2)	1
116	M10 D10 SPRING WASHER	1
117	FLAT WASHER D10.5X22ODX3T D10.5XD22X3t	1
118	GRADUATED RULER / SCALE	1
119	DRIVE SCREW D2X5mm	2
120	WASHER D10.5XD28X4t	1
121	LOCK NUT M10X1.5 M10	1
122	ADJUSTING RING	1
124	SPRING	1
127	HEXAGONAL CYLINDRICAL HEAD SCREW + WASHER M5X16mm SCM435	2
128	FLAT WASHER D5.2XD10X1.5t	2
129	ADJUSTING SCREW M5X10mm	1
130	REINFORCEMENT SUPPORT	1
131	TM-3 CONNECTION WIRE (C5)	3
132	M8X45MM HEXAGON HEAD SCREW	1
133	ADJUSTING SCREW M5X10mm	1
134	M8X1.25 HEX NUT M8	1
137	SHAFT S20C	1
138	ANGLE FASTENING BRACKET	1
139	M8X45MM HEXAGON HEAD SCREW	1
140	8MM HEXAGONAL WRENCH 8x100mm	1
141	SHEATH FOR LARGE NBR WRENCH	1
142	HEXAGONAL WRENCH WITH FLOWER HEAD SCM435	1
143	SHEATH FOR SMALL WRENCH NBR	1
144	FLAT HEAD SCREW	4
153	ROUND SKID	2
157	BASE	1
157A	100X29MM WHITE ALUMINUM PLATE	1
158	CYLINDRICAL HEAD SCREW + WASHER M4X0.7X12mm	6
159	SPCC CHIP TRAY FASTENING PLATE	3
160	SPCC DRAWER	1
161	1/4-20UNC HEX NUT	1

162	FLAT WASHER 1/4X13X1.5t"	1
163	ELASTIC WASHER 1/4"	1
164	BUTTON 1/4-20UNCX15mm"	1
166	PA-8-2 TERMINAL BLOCK	1
167	3/4" THICKNESS SLEEVE	1
168	COVER	1
170	SOFT START MODULE WITH 230V FILTER	1
170A	FEIN LABEL (30x5mm)	1
171	CYLINDRICAL HEAD SCREW / WASHER M5X14mm	2
172	SHOULDER SCREW	1
173	SHOULDER SCREW	1
174	SHOULDER SCREW	1
175	SHEATH D11.06xD10x0.53tx90mm	1
176	SHEATH D8.9xD8x0.45tx195mm	1
177	CABLE CLIP ALT-120S	4
178	JUMPING WIRE 16X80mm(BLUE)	1
179	JUMP WIRE 16AWGX220mm BROWN	1
180	FIBER PLATE	2
181	STEERING WHEEL	1
182	ADJUSTING SCREW 5/16X15mm"	1
183	CIRCUIT BREAKER / THERMAL PROTECTION 10A	1
186	ADJUSTING SCREW M4X4mm	1
187	PIN	1
188	BRIDGE WIRE 14X190MM (YELLOW) 14X190mm(YELLOW)	1
221	SHEATH D9X8.4X0.3tx210mm	1
222	SPO SAFETY PROTECTION	1
223	AXLE / PIVOT T.S.AAS 6-3	2

10 ELECTRICAL DIAGRAM

PTMC355 ELECTRICAL DIAGRAM

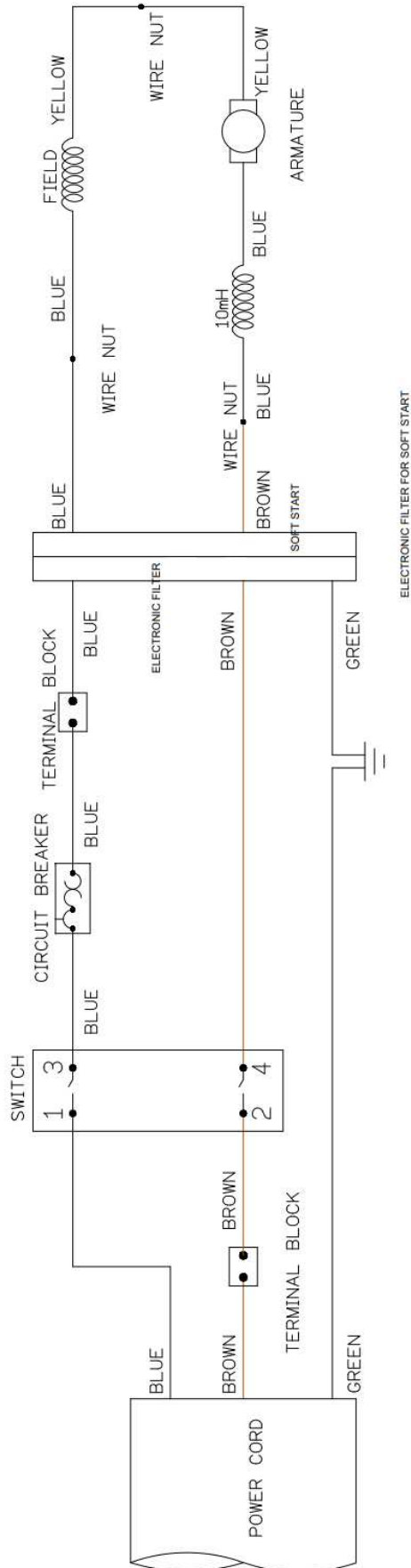

11 NOISE LEVEL

The data relating to the noise level emitted by this machine during operation will depend on the type of material being ground and the type of grinding wheel. For this reason, the measurement data is relative.

The risk of hearing damage to the operator depends on the length of exposure to noise.

The operator must wear ear defenders or other appropriate personal protective equipment when the sound power exceeds 85 dB(A) in the workplace.

- Sound pressure level (1 m at no load):
L_{pA} = 90 dB(A)
- Sound power level (1 m at no load):
L_{wA} = 103.6 dB(A)

The sound power was calculated taking into account factors such as: reverberation at the test site, ground noise absorption, and other factors that may interfere with the measurements. This estimate allows us to state that the degree of error in the values obtained is around 3 dB(A).

The values given are emission levels and not necessarily levels that allow for safe working. Although there are correlations between emission levels and exposure levels, these cannot be used reliably to determine whether additional precautions are necessary. Parameters that influence actual exposure levels include workshop characteristics, other sources of noise, etc., i.e., the number of machines and neighboring manufacturing processes. In addition, permissible exposure levels may vary from country to country. However, this information allows the machine user to make a better risk assessment.



12 VIBRATION LEVEL

The vibration data transmitted by this machine during operation will depend on the type of material used and the type of disc. For this reason, the measurement data is relative.

Exposure to vibrations can have serious consequences for the health of workers. A person exposed to high-amplitude vibrations on a daily basis may develop neurological and joint disorders in the long term.

These values must be taken into account when assessing the level of exposure.

Regular and frequent exposure to a highly vibrating work disc exposes workers' hands and arms to chronic disorders known as "vibration syndrome."

- Average hand/arm vibration level:
A(8) < 2.7 m/s²

The exposure level assessment is based on the calculation of the daily exposure value A(8), normalized to a reference period of 8 hours.

Whenever an employee is exposed to A(8) vibrations exceeding the daily exposure level triggering action set at 2.5 m/s², the employer must assess the risks of the task assigned to the employee and implement control measures.

Exposure values for vibrations transmitted to the hand-arm system:

- Daily exposure limit value:
A(8) = 5 m/s²
- Daily exposure value triggering action:
A(8) = 2.5 m/s²

13 ENVIRONMENTAL PROTECTION

Your machine contains many recyclable materials.
This logo indicates that used machines must not be mixed with other waste.
This will ensure that the machines are recycled under the best conditions, in accordance with European Directive 2012/19/EU on waste electrical and electronic equipment.
Contact your local council or dealer to find out where your nearest collection points for used machines are located.
Thank you for your cooperation in protecting the environment.



14 WARRANTY

If the machine is covered by warranty, it must be serviced exclusively by an authorized after-sales service center.
The machine warranty is valid for 2 years from the date of purchase by the user.
This product benefits from an additional 2-year warranty extension, provided that the user registers the product on the PEUGEOT OUTILS PROFESSIONNELS website (www.peugeot-outils-pro.com) within 30 days of the date of purchase. This warranty extension is subject to the same conditions as the initial warranty.
Accessories and consumables are not covered by the warranty.
It is important to keep the invoice, which serves as the warranty certificate.
The warranty is limited to the repair or replacement of defective parts free of charge, after evaluation by the manufacturer.
For any requests for information or spare parts relating to the machine, it is essential to provide the exact information shown on the nameplate.
The warranty does not cover damage caused by the user or by a repairer not approved by Tivoly.
Link to the General Warranty Terms and Conditions:



CE AL DECLARATION OF CONFORMITY "ORIGINAL"

The undersigned (Manufacturer/Importer):

TIVOLY

266 ROUTE PORTES DE TARENTEISE 73790 TOURS-EN-SAVOIE

Declares that the following new machine:

- Designation: **DRY CUT METAL SAW WITH CARBIDE BLADE**
- Brand: **PEUGEOT PROFESSIONAL TOOLS**
- Model: **PTMC355**
- Reference: **PPM00200002**
- Serial number:

Complies with applicable harmonized legislation:

- **Machinery Directive 2006/42/EC (until January 19, 2027)**
- **EU Regulation 2023/1230 (from January 20, 2027)**

Complies with the essential safety requirements applicable to it:

- **Low Voltage Directive 2014/35/EU**
- **Electromagnetic Compatibility Directive 2014/30/EU**
- **WEEE Directive 2012/19/EU**
- **RoHS-2 Directive 2011/65/EU**
- **REACH 1907/2006**
- **Noise Directive 2003/10/EC**
- **Vibration Directive 2002/44/EC**

Done at TOURS-EN-SAVOIE
On

Stéphane Le Mounier
Managing Director



Person authorized to compile the technical file:

- Mr. LE MOUNIER – TIVOLY – 266 ROUTE PORTES DE TARENTEISE 73790 TOURS-EN-SAVOIE

	TIVOLY: Registered office: 266 ROUTE PORTES DE TARENTEISE 73790 TOURS-EN-SAVOIE www.peugeot-outils-pro.com	USER SERVICE Tel: +33(0)4 79 89 59 00
	In its ongoing effort to improve the quality of its products, TIVOLY reserves the right to modify their characteristics. The information, photos, exploded views, and diagrams contained in this document are not contractual.	Published by april 2026 Instruction manual PTMC355