



Get a free 2-year warranty



DE / FR / PT / SP

BENCH GRINDER

PTMM150

IN GOOD HANDS

TRANSLATION OF ORIGINAL INSTRUCTION MANUAL





WHO ARE WE?

Peugeot Professional Tools was born out of several obvious considerations.

The first was to combine the know-how of **Peugeot**, which has mastered the art of cutting since 1810, with the expertise of **Tivoly**, a metalworker since 1917, in order to create a wide range of machines and tools for construction and maintenance professionals.

It was also a natural step to want to serve craftsmen and small businesses driven by strong family and heritage values.

For these professionals, **Peugeot Outils Professionnels** offers machines and tools designed specifically for their needs. **These tools are reliable, durable, and can be repaired in France** and in countries under distribution agreements by local industrial and family partners.

Trustworthy equipment with a longer warranty, logistics, and

French after-sales service. The assurance of dealing with the people who assembled these tools and know every part that goes into them inside out.

From exceptional projects to everyday work, these tools are designed to withstand the most demanding conditions and stand the test of time.

Peugeot Professional Tools was born out of one obvious fact: that our tools are in good hands. The hands of those who work behind the scenes and give their all to satisfy their customers.

Since 1810, many things have changed, but the hands have remained the same. The hands of enthusiasts, craftsmen, dedicated technicians and installers, workers who are proud of themselves and their achievements.

Peugeot Professional Tools: tools in good hands.

THANK YOU FOR YOUR PURCHASE.

We are delighted that you have chosen Peugeot Professional Tools. Every detail has been designed to offer you an exceptional experience, and we hope you enjoy using it as much as we enjoyed creating it for you.

Your trust is essential to us, and we are delighted to accompany you every step of the way in your experience with the Peugeot Professional Tools brand.

Your purchase comes with a 2-year warranty, extendable to an additional 2 years.













To benefit from this, register at www.peugeot-outils-pro.com

If you have any questions or need assistance, our team is available to provide you with the best possible service.

To contact our after-sales service, visit www.peugeot-outils-pro.com, call [+33\(0\)4.79.89.59.00](tel:+330479895900), or email service@peugeot-outils-pro.com.

Thank you for choosing Peugeot Professional Tools. Your satisfaction is our priority.

TABLE OF CONTENT

1	INTRODUCTION	4
2	PICTOGRAMS	4
2.1	MACHINE SAFETY PICTOGRAMS	4
2.2	PICTOGRAMS USED IN THIS INSTRUCTION MANUAL	4
3	SAFETY	5
3.1	GENERAL SAFETY REQUIREMENTS.....	5
3.2	SPECIAL SAFETY REQUIREMENTS.....	6
3.3	OPERATOR PROTECTION	6
4	DESCRIPTION AND OPERATION	7
4.1	INTENDED USE OF THE MACHINE.....	7
4.	CHARACTERISTICS	7
4.3	DESCRIPTION OF THE MACHINE.....	7
5	INSTALLATION	8
5.1	 PACKAGING.....	8
5.2	 HANDLING AND TRANSPORT	8
5.3	 INSTALLATION OF THE MACHINE	8
5.4	 ASSEMBLY	9
5.5	 ELECTRICAL CONNECTION.....	10
5.6	 INITIAL TEST AND INSPECTION BEFORE FIRST USE.....	10
6	USE	11
6.1	GRINDING PROCEDURE.....	11
7	MAINTENANCE	13
7.1	 ADJUSTMENTS.....	13
7.2	 PROTECTIVE SCREENS.....	13
7.3	 CLEANING.....	13
7.4	 LUBRICATION.....	13
7.5	 TAKING THE MACHINE OUT OF SERVICE	13
7.6	 REPLACING A BENCH GRINDER	14
8	EXPLODED VIEW	15
9	ELECTRICAL DIAGRAM	17
10	SOUND LEVEL	18
11	VIBRATION LEVEL	18
12	ENVIRONMENTAL PROTECTION	19
13	WARRANTY	19
14	DECLARATION OF CONFORMITY	20

1 INTRODUCTION



**For safety reasons, read these instructions carefully before using this machine.
Failure to follow the instructions will result in damage to persons and/or the machine.**

This instruction manual is intended for the operator, adjuster, and maintenance personnel.

This instruction manual is an important part of your equipment. It provides rules and guidelines that will help you use this machine safely and efficiently. You must familiarize yourself with the functions and operation by reading this instruction manual carefully. For your safety, it is particularly important that you read and observe all recommendations on the machine and in this instruction manual.

These recommendations must be strictly followed at all times when using and maintaining the machine. Failure to follow the safety guidelines and warnings in the instruction manual and on the machine and/or use other than that recommended in the instruction manual may result in machine failure and/or injury.

Please keep this instruction manual with the machine or in a place that is easily accessible at all times for future reference. Ensure that all personnel involved in the use of this machine can consult it periodically.

If the instruction manual is lost or damaged, please contact us or your dealer to obtain a new copy.

Always use PEUGEOT OUTILS PROFESSIONNELS components and parts. Replacing components or parts other than PEUGEOT OUTILS PROFESSIONNELS may cause damage to the machine and endanger the operator.

This manual describes the safety instructions to be followed by the user. It is the responsibility of the employer or user, in accordance with Article L.4122-1 of the Labor Code, to take care of their health and safety and that of other persons affected by their actions or omissions, in accordance, in particular, with the instructions given to them.

The employer must carry out an assessment of the specific risks associated with their activity, must train workers in the use of the machine and in the prevention of these risks, and must appropriately inform workers responsible for the use or maintenance of work equipment of the instructions or guidelines that apply to them.

2 PICTOGRAMS

2.1 MACHINE SAFETY PICTOGRAMS

Meaning of the safety pictograms affixed to the machine (keep them clean and replace them when they are illegible or detached):



Wearing protective eyewear is mandatory



Hearing protection must be worn



Gloves must be worn



Safety shoes must be worn



Respiratory mask must be worn



Do not wear loose clothing, wide sleeves, jewelry, bracelets, watches, wedding rings, etc.
Wear hair nets for long hair



Read the instructions carefully

2.2 PICTOGRAMS USED IN THESE INSTRUCTIONS



Direct danger to people and damage to the machine



Possible damage to the machine or its surroundings



Wear protective gloves when changing tools and cleaning

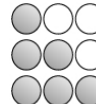

Technical skill level: operator, user

Technical skill level: adjuster, maintenance

Technical skill level: maintenance technician



Note



Electrical operations must be performed by personnel who are qualified and authorized to perform low-voltage electrical work.

3 SAFETY

3.1 GENERAL SAFETY REQUIREMENTS



To reduce the risk of fire, electric shock, mechanical shock, and personal injury when using power tools, follow basic safety precautions.

This instruction manual only takes into account reasonably foreseeable behavior.

Our machines are designed and manufactured with operator safety in mind.

We accept no liability for damage caused by inexperience, incorrect use of the machine and/or damage to it and/or failure to comply with the instructions and safety rules contained in this instruction manual.

As a general rule, accidents always occur as a result of misuse or failure to read the instruction manual.

We remind you that any modification to the machine will result in our disengagement.

Check the presence, condition, and operation of all protective devices before starting work.

Ensure that moving parts are functioning correctly, that there are no damaged components, and that the machine is operating perfectly during commissioning.

Only competent and authorized personnel are permitted to repair or replace damaged parts.

Keep the work area clean and tidy.

Ensure that the entire work area is visible from the work position. Cluttered work areas and workbenches are a potential source of injury.

Do not use the machine outdoors, in very humid conditions, or in the presence of flammable liquids or gases.

Position the machine in a sufficiently lit work area.

The machine must not be used by young workers under the age of eighteen.

Do not allow unauthorized persons, especially children or animals, to enter the work area, touch the tools or electrical cables, and keep them away from the work area.

Never leave the machine unattended while it is in operation. Always disconnect the power supply. Only leave the machine when it has come to a complete stop.



Do not force the tool; it will perform better and be safer at the speed for which it is designed.

Do not force small tools to do the work of larger tools.

Do not use tools for jobs for which they are not intended.



Do not damage the power cord.

Never pull on the power cord to remove it from the electrical outlet.

Keep the power cord away from heat sources, greasy areas, and/or sharp edges.

Protect the power cord from moisture and any potential damage. Check the power cord periodically and, if damaged, have it repaired by an authorized repairer.

A defective switch must be replaced by an authorized service center.

Do not use the machine if the switch does not control the stop or start functions.



Do not overestimate your strength.

Always maintain a stable position and good balance.

Pay attention to what you are doing, use common sense, and do not use the machine when tired.

Always use both hands to operate this machine.

The use of any accessories other than those described in the instruction manual may present a risk of injury to persons.

The user is responsible for their machine and must ensure that: The reel is used by people who have read the instructions and are authorized to do so.

Safety rules are followed.

Users have been informed of the safety rules.

Users have read and understood the instruction manual.

Responsibilities for maintenance and any repairs have been assigned and observed.

Defects or malfunctions have been immediately reported to an authorized repairer or your dealer.

The reel must be used in the areas of application described in this manual.

Any use other than that indicated in these instructions may constitute a hazard.

Mechanical and/or electrical guards must not be removed or bypassed.

No modifications and/or conversions should be made.

PEUGEOT OUTILS PROFESSIONNELS declines all responsibility for damage caused to persons, animals, or objects as a result of failure to comply with the instructions and safety rules contained in this instruction manual.

3.2 SPECIAL SAFETY REQUIREMENTS



When a material that is hazardous to health is machined or used, or when there is a risk of dust emissions, the protective devices are designed to reduce the operator's exposure as much as possible. For this reason, a suitable extraction system must be used.



This grinder is not designed for machining materials that can produce flammable or explosive dust, such as aluminum, magnesium, and their alloys.

Allow the bench grinders to reach their maximum speed before starting to machine.

Adjust the protective screens and spark guards to protect the operator from flying sparks.

Wearing appropriate personal protective equipment is mandatory.

Always hold the workpiece correctly with both hands.

Do not strike the workpiece against the bench grinder; apply pressure gradually.

Cool the workpiece from time to time in a water tank.

Do not touch the bench grinders while they are in motion.

Wait until the bench grinders have come to a complete stop before handling the grinder.

Before performing any maintenance or servicing, disconnect the power supply.

During continuous use, be careful of the surface of the grinder, as there is a risk of burns.

Do not add additional accessories for operations for which they are not designed.

Using an inappropriate accessory may result in accidents.

Do not mount a brush in place of a bench grinder.

Do not use damaged bench grinders.

Before installing a new bench grinder, check that it is in good condition (see section 7.6 "Replacing a bench grinder").

Only use bench grinders recommended by PEUGEOT PROFESSIONAL TOOLS with a speed equal to or greater than the speed indicated on the tool's nameplate.

Always keep bench grinders clean.

Do not clean bench grinders while they are in motion.

When cleaning, wear protective goggles and gloves, and use a brush and a clean, dry cloth.

Do not immerse the machine in water or wash it with a pressurized water jet, as this may cause water to enter the electrical components.

Do not use solvents or aggressive detergents.

Store the machine in a dry place out of the reach of children.



Hazards:

Mechanical:

- Risk of entanglement or entanglement for the operator during manual operations near a bench grinder.
- Risk of the operator being dragged in or trapped during manual operations between a bench grinder and the elements of the grinder, especially near the workpiece support or between a bench grinder and the workpiece.
- Risk of friction or abrasion for the operator during accidental contact with a rotating bench grinder.

Materials and products:

- Risk of inhalation of harmful dust released by bench grinders for the operator or other persons with access to the area around the grinder during grinding operations.

Fall or overturning of the machine:

- Risk of injury to the operator if the grinder or base are not secured.

3.3 OPERATOR PROTECTION



For operator safety, ensure that the protective screens and bench grinder guards are in good condition and in place. Ensure that non-working parts are always covered by a protective guard.

This machine is designed for a single operator.

The operator must wear appropriate personal protective equipment:

- Safety glasses.
- Hearing protection.
- Safety shoes.
- Protective gloves.
- Respiratory protection.

The operator must wear close-fitting clothing and, if necessary, hair coverings for long hair.

The operator must not wear, for example:

- Loose-fitting clothing with wide sleeves.
- Bracelets, watches, wedding rings, jewelry.
- Any other objects that could become caught in the moving parts of the machine.



4 DESCRIPTION AND OPERATION

4.1 INTENDED USE OF THE MACHINE

The PTMM150 bench grinder is a bench or pedestal grinder intended for regular use in dry tangential grinding of ferrous metals (grinding a workpiece surface using the periphery of the bench grinder).

The manufacturer declines all responsibility in the event of misuse or grinding of materials other than those mentioned above. Under proper conditions of use and maintenance, safe operation and work are guaranteed for several years. To do this, explore the machine's various functions.

4.2 CHARACTERISTICS

- European manufacture
- Cast aluminum body
- Mounted on sealed, self-lubricating ball bearings
- On/off switch equipped with a safety device with a voltage failure coil
- Locking punch stop
- Polycarbonate protective screens
- Internal automatic thermal protection in the motor
- Pressed steel casings equipped with a dust collection nozzle
- Safety and compliance:
 - space between the bench grinder and the lower casing less than 5 mm
 - spark guard and tool holders adjustable to 2 mm from the bench grinder
 - no opening under the tool holder

	Bench grinder/Bench grinder (mm)		Grit of bench grinder		Rotation Rotation (rpm)	Power	Motor power (kW)	Weight (kg)	Dimensions (W x D x H) (mm)
PTMM150	150 x 20 x 16	150 x 20 x 16	A 24 R	A 60 M	2800	230 V single-phase	0.375	12.6	410 x 270 x 215

4.3 MACHINE DESCRIPTION



1. Straight bench grinder housing
2. Bench grinder A 60 M
3. Adjustable spark guard, right
4. Straight protective screen
5. Straight tool holder
6. A 24 R bench grinder
7. Left bench grinder guard
8. Left tool holder
9. Adjustable spark guard, left
10. Left protective screen
11. ON/OFF switch with lock-off punch stop
12. Base
13. Mounting holes
14. Dust collection nozzle

5 INSTALLATION

5.1 PACKAGING



A small moisture-proof bag may be included in the packaging. Keep it out of the reach of children and dispose of it.

The reel is packaged in a cardboard box for easy handling and storage.

When unpacking, remove each part of the reel, check its overall condition, and then proceed with assembly.

If the product does not appear to be in good condition or if any parts are broken or missing, contact your retailer. Keep the instruction manual for future reference.

5.2 HANDLING AND TRANSPORT

Given the weight (12.6 kg) and dimensions of the machine, it can be handled by a single person.

5.3 INSTALLING THE MACHINE



Secure the reel to a suitable base or workbench using the anchor points provided on the base. Connect a suitable extraction system to the dust collection nozzles, if necessary.



To position the machine at the workstation, install the reel at a height that allows for comfortable working. The recommended height of the support is 70 to 80 cm from the floor.



Installation environment:

- Power supply voltage in accordance with the machine's specifications.
- Ambient temperature between +5°C and +35°C.
- Relative humidity not exceeding 90%.
- Sufficient ventilation at the installation site.
- Work area sufficiently lit for safe working: lighting must be 500 LUX.

Procedure:

1. Secure the base or workbench to the floor.
2. If necessary, fill the base with sand to reduce any vibrations and stabilize the unit.
3. Secure the drum to the base or workbench by inserting 4 screws (M8) into the holes (13 fig.1) and then tighten them firmly using appropriate nuts.

✓ For safety reasons, we remind you that it is mandatory to secure the drum on a base or workbench.



There is a risk of breaking the reel support if it is tightened excessively on a deformed surface.

5.4 ASSEMBLY



The spark guards and tool holders must be adjusted regularly as the bench grinders wear down to maintain the specified distance from the outer edge of the bench grinders.



Ensure that the bench grinder clamping nuts are securely tightened and check the integrity of the bench grinders before use (see section 7.6 "Replacing a bench grinder").



Replace a bench grinder when it has reached a diameter of 110 mm.
Do not mount/use a bench grinder with a diameter of less than 110 mm.

Left bench grinder side:

1. Attach the spark guard (35) to the bench grinder covers (3 and 29) and adjust it to a maximum of **5 mm** from the outer edge of the bench grinder.
2. Attach the transparent protective screen (27) to the spark guard (35) and adjust it to protect the operator.
3. Attach the tool holder (28) to the bench grinder covers (3 and 29) and adjust it to a maximum of **2 mm** from the peripheral edge of the bench grinder.

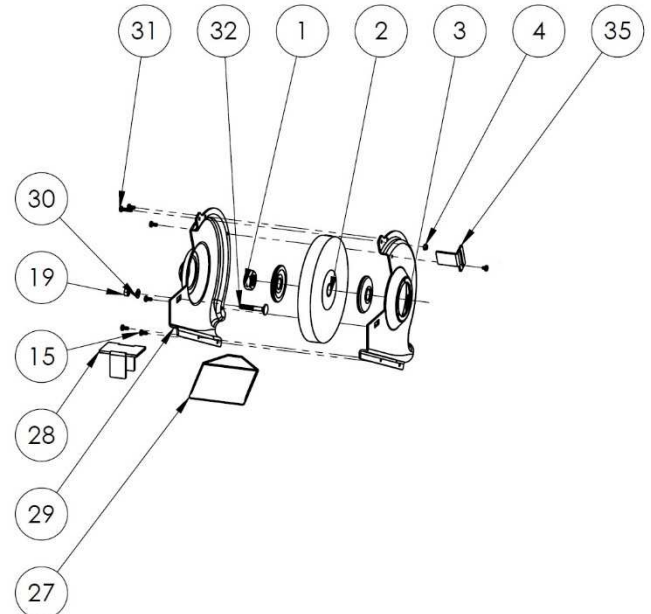

4. The diameter of a bench grinder decreases as it wears down and its distances increase.

Right bench grinder side:

5. Attach the spark guard (33) to the bench grinder covers (12 and 16) and adjust it to a maximum of **5 mm** from the outer edge of the bench grinder.
6. Attach the transparent protective screen (27) to the spark guard (33) and adjust it to protect the operator.
7. Attach the tool holder (28) to the bench grinder covers (12 and 16) and adjust it to a maximum of **2 mm** from the peripheral edge of the bench grinder.



8. The diameter of a bench grinder decreases as it wears down and its distances increase.

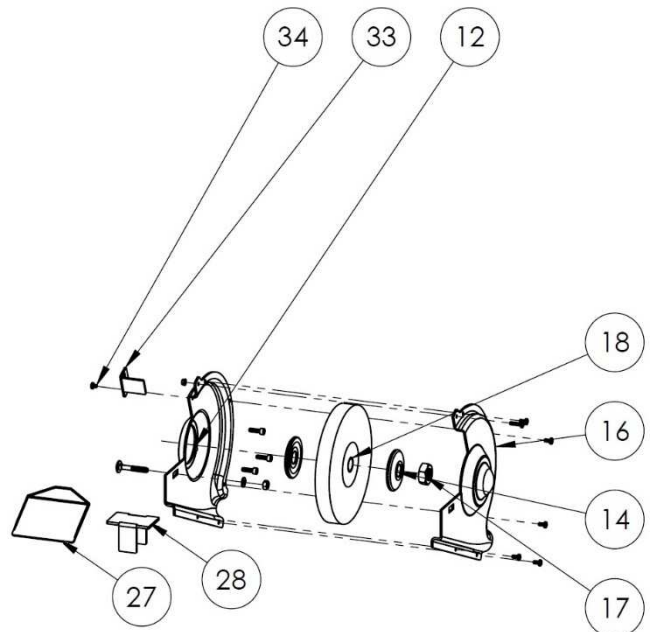

5.5 ELECTRICAL CONNECTION



Electrical work must be carried out by qualified personnel authorized to perform low-voltage electrical work.



**Check that the bench grinders rotate in the same direction as indicated by the arrow on the bench grinder housings.
The warranty does not cover damage caused by incorrect connection.**



ELECTRICAL SUPPLY

Ensure that the mains supply voltage corresponds to that of the machine and that the electrical outlet is in good condition and earthed.

Check that the electrical outlet in your installation is compatible with the plug on the machine's power cable.

The electrical outlet must comply with "EN 60309-1" standards.

Connect the machine using the power cable.

Ensure that the machine switch is in the "0" position.

Check that the electrical installation to which the machine will be connected is properly grounded in accordance with current safety standards.

We remind users that there must always be a magnetothermal protection device upstream of the electrical installation to protect all conductors against short circuits and overloads.

This protection must always be selected based on the electrical characteristics of the machine, as specified on the nameplate:

- Voltage: 230 V single-phase
- Frequency: 50 Hz
- Current: 2.63 A
- Motor power: 0.375 kW



**Use cables and reels of a cross-section and length appropriate for the power of the machine and unroll them completely.
Electrical connections and extension cords must be protected from splashes and kept on dry surfaces.**



**Use of the machine with a damaged power cable is strictly prohibited.
Regularly check the condition of the power cord, cable gland, and switch.**



Do not remove the plug from the electrical outlet by pulling on the power cord; pull only on the plug.

5.6 INITIAL TEST AND INSPECTION BEFORE FIRST USE

- Check that the protective devices are present, intact, and in good working order.
- Check that the moving parts are working properly and that there are no damaged components.
- Check the condition of the bench grinders.
- Check that the wheel is securely attached to the workbench or its base and that the base is secured to the floor.
- Check that the machine operates perfectly when idle.

6 USE



Follow the specific safety instructions for grinders.



Before starting operation, familiarize yourself with the controls.



Ensure that the bench grinder clamping nuts are securely tightened and check the integrity of the bench grinders before use (see section 7.6 "Replacing a bench grinder").



Before any maintenance or servicing, disconnect the power supply.



Wearing appropriate personal protective equipment is mandatory.



During continuous use, be careful of the surface of the grinder, as there is a risk of burns.



We urge you to periodically check the condition of your grinder, in particular the distance between the tool holder and the bench grinder, the condition of the bench grinders, and the condition of the power supply.

6.1 GRINDING PROCEDURE



Keep your hands away from the machining areas when the machine is in operation.



During machining, there is a risk of sparks or debris being projected.



Manual grinding must always be carried out with great care, as there is a risk of contact with the bench grinder (entrapment, burns, pinching, abrasion, or crushing).



In the event of significant vibrations, identify the bench grinder that is out of balance and rectify it with an appropriate tool to rebalance it.



Tool holders must always be used in a horizontal position.
Screens must always be kept clean.



Do not apply excessive pressure to the tool. Machining performance is not improved by applying high pressure to the tool, but the service life of the tool and machine will be reduced.

Operating cycle

A. Grinding instructions:

1. Adjust the protective screens (15 fig. 2), spark guards (32 and 33 fig. 2), and tool holders (26 fig. 2) so as to avoid any contact with a bench grinder.
2. Ensure that you are equipped with protective equipment.
3. Always wear protective eyewear.
4. Plug the power cord (18 fig. 2) of the angle grinder into the electrical outlet.
5. Unlock the switch's safety lock (19 fig. 2).
6. Press the green "I" button on the switch (19 fig.2) to start the motor and allow the bench grinders to reach their speed.
7. Gradually bring the workpiece into contact with the bench grinder, leaning on the tool support.
8.  The workpiece must always be held with both hands and cooled from time to time in a water tank.

Left-hand bench grinder

- The bench grinder (30 fig. 2) has a coarse grain (A 24 R) and is suitable for dry deburring work on ferrous metals (steel, iron, hard cast iron) for heavy material removal and rapid sizing of parts.
- Original bench grinder: A 24 R gray corundum: Ø 150 x 20 x 16 mm (reference: PPA602401501)

Right-hand bench grinder

- The bench grinder (31 fig.2) has a fine grain (A 60 M) and is suitable for dry sharpening tools (axes, sickles, drills, chisels, blades, etc.) made of hard metals.
- Original bench grinder:
A 60 M gray corundum
Ø 150 x 20 x 16 mm (reference: PPA603401501)



**Allow the bench grinders to reach their maximum speed before starting to machine.
Do not slow down or block the bench grinders by applying excessive pressure.**



Spark guards and tool holders must be adjusted regularly as the bench grinders wear down to maintain the specified distance from the outer edge of the bench grinders.

B. Stopping:

- Press the lock-in emergency stop button (19 fig. 2) to stop the wheel, which will continue to rotate for a few seconds before coming to a complete stop.



Wait until the bench grinders have come to a complete stop before handling the bench grinder.

7 MAINTENANCE



Disconnect the power supply before performing any maintenance or servicing.
Wear gloves and protective eyewear, and use a clean, dry cloth, brush, long-handled brush, hook, magnetic collector, or vacuum cleaner for all cleaning operations.



Do not use an air gun to remove dust.
Do not use solvents or aggressive detergents.
Do not immerse the machine in water or wash it with a water jet.

To maintain the efficiency of the reel and its components, it is necessary to perform maintenance on the machine. The most important maintenance tasks are listed below.

Failure to perform the prescribed tasks will result in premature wear and reduce the performance of the machine.



7.1 ○○○ ADJUSTMENTS

Regularly check the distances in relation to the wear of the bench grinder:

- The spark guards must be set to a maximum of 5 mm from the outer edge of the bench grinder.
- Tool holders must be set to a maximum of 2 mm from the peripheral edge of the bench grinder.

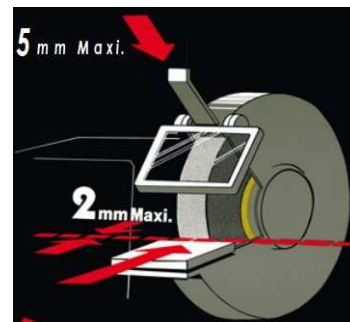

7.2 ○○○ PROTECTIVE SCREENS

- Regularly check that the protective screens are clean and replace them if they are damaged.
- Maximum service life of a protective screen: 2 years.

7.3 ○○○ CLEANING

- Clean the grinder regularly, especially inside the bench grinder housing, to prevent a build-up of machining dust.

7.4 ○○○ LUBRICATION

- The motor bearings are lubricated for life and require no maintenance.

7.5 ○○○ TAKING THE MACHINE OUT OF SERVICE

If the reel is not to be used for an extended period of time, it is recommended to proceed as follows:

1. Disconnect the power plug from the power supply.
2. Clean the machine carefully.
3. Cover the machine, if necessary.

7.6  REPLACING A BENCH GRINDER

Disconnect the machine from the power supply before performing this operation.



**Do not install a brush in the bench grinder housing or brush housing.
Replace bench grinders with models of the same weight and dimensions.**



**Replace a bench grinder when it reaches a diameter of 110 mm.
Do not install/use bench grinders with a diameter of less than 110 mm.**



Do not use damaged bench grinders.



Only use bench grinders recommended by PEUGEOT OUTILS PROFESSIONNELS with a speed equal to or greater than the speed indicated on the tool's nameplate.



Checking the integrity of a new bench grinder:

Before installing a new bench grinder, perform a sound test to check its overall condition:

1. To perform this test, the bench grinders must be dry and clean. Otherwise, the sound emitted may be weakened.
2. Using a non-metallic object (wooden handle of a screwdriver or wooden mallet), tap lightly on the side of the bench grinder: a light tap on an intact bench grinder produces a clear, pleasant sound.
3. On the other hand, if the sound emitted is dull or cracked, the bench grinder should not be used.



Handle bench grinders with care. If a bench grinder has been knocked or dropped, do not use it (always refer to the instructions supplied with the bench grinder).



We recommend the use of vitrified bench grinders. Different qualities are available.

Refer to the table on the bench grinders or, for more details, to our self-service packaging of bench grinders for bench grinders.

Procedure:

1. Ensure that the power cable (18 fig. 2) is disconnected.
2. Remove the spark guard (32 or 33 fig. 2) and the tool holder (26 fig. 2).
3. Remove the outer bench grinder housing (12 or 13 fig. 2) by unscrewing the screws (14 fig. 2).
4. Hold the rotor shaft (3 fig. 2) in position using a hex key on the end of the shaft.
5. Unscrew the bench grinder nut with a flat wrench (10 or 11 fig. 2).
6.  The nut on the left side (11 fig. 2) has a left-hand thread, which means it must be loosened in a clockwise direction.
7. Remove the outer bench grinder flange (9 fig. 2).
8. Replace the worn bench grinder (30 or 31 fig. 2) with a new one (make sure the flanges and mounting shaft are clean before refitting a bench grinder).
9. Check that the bore of the bench grinder matches the bench grinder shaft. Use reduction rings if necessary.
10. Refit the outer bench grinder flange (9 fig. 2).
11. Screw the clamping nut (10 or 11, fig. 2) back on and tighten it firmly, but without overdoing it. This nut tends to lock itself due to its own inertia.
12. Refit the outer bench grinder cover (12 or 13 fig. 2).
13. Ensure that the lateral distance between the bench grinder and the casing is less than 10 mm.
14. Reassemble the previously disassembled components.

8 EXPLODED VIEW

EXPLODED VIEW PTMM150 (VIEW 01)

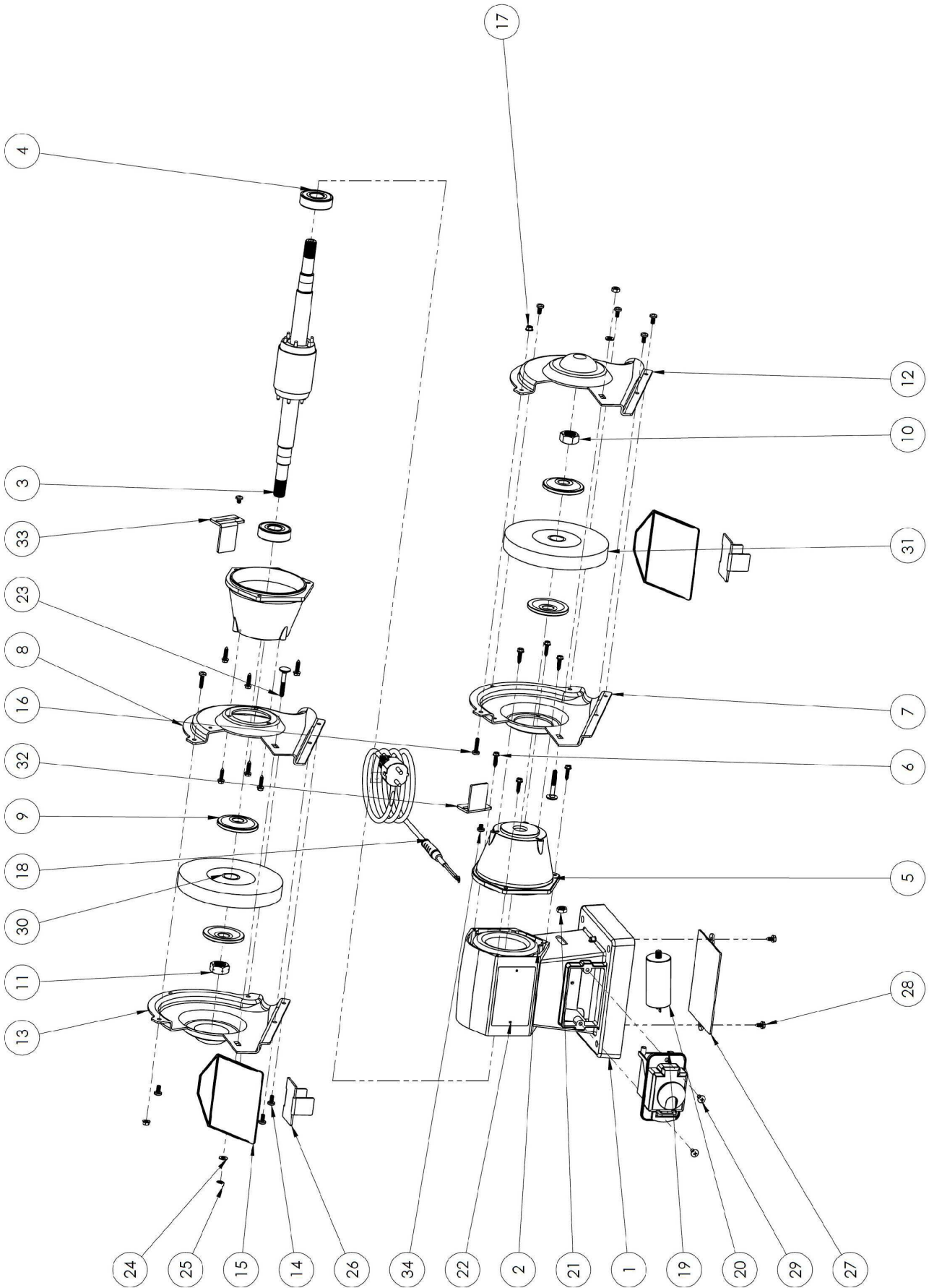

PARTS LIST EXPLODED VIEW PTMM150 (VIEW 01)

Reference	Description	Quantity
01	MOTOR FRAME 0.375KW #RAL 9004	1
02	STATOR 230V 50HZ 0.375KW #RAL 9004	1
03	ROTOR 0.375KW TE151	1
04	BEARING 6204 ZZ	2
05	MOTOR HOUSING 0.375KW D. 150MM #RAL 9004	2
06	SCREW 4.8X19	12
07	INSIDE BENCH GRINDER HOUSING RIGHT SIDE D. 150MM #RAL 2008	1
08	INSIDE BENCH GRINDER COVER LEFT SIDE D. 150MM #RAL 2008	1
09	FLANGE FOR DIA150MM	4
10	M16 BENCH GRINDER CLAMPING NUT, RIGHT SIDE	1
11	M16 BENCH GRINDER CLAMPING NUT, LEFT SIDE	1
12	OUTER BENCH GRINDER COVER, RIGHT SIDE, D. 150MM #RAL 2008	1
13	OUTER BENCH GRINDER COVER, LEFT SIDE, D. 150MM #RAL 2008	1
14	5X10 SCREW	8
15	PROTECTIVE SCREEN	2
16	5X20 SCREW	2
17	M5 NUT	2
18	ELECTRICAL POWER CABLE H05VV-F 3X0.75MM ²	1
19	230V Single Pole Switch	1
20	12 μ F CAPACITOR	1
21	M8 NUT UNI 5589	1
23	6X40 BOLT UNI 5732	2
24	M6 WASHER UNI 6592	2
25	M6 NUT UNI 5588	2
26	TE DIA 150MM TOOL HOLDER	2
27	0.375KW MOTOR FRAME PROTECTION PLATE	1
28	SCREW 4.8X9.5 UNI 6950 -7976	2
29	4.8X13 SCREW	2
30	XPLR+MT A24R BENCH GRINDER, GREY CORUNDUM, D.150 X 20 X 16	1
31	XPLR+MT A60M BENCH GRINDER, GRAY CORUNDUM, D.150 X 20 X 16	1
32	SPARK ARRESTOR RIGHT SIDE	1
33	SPARK GUARD LEFT SIDE	1
34	SCREW 5X6 UNI 7985	2

9 ELECTRICAL DIAGRAM

PTMM150 ELECTRICAL DIAGRAM

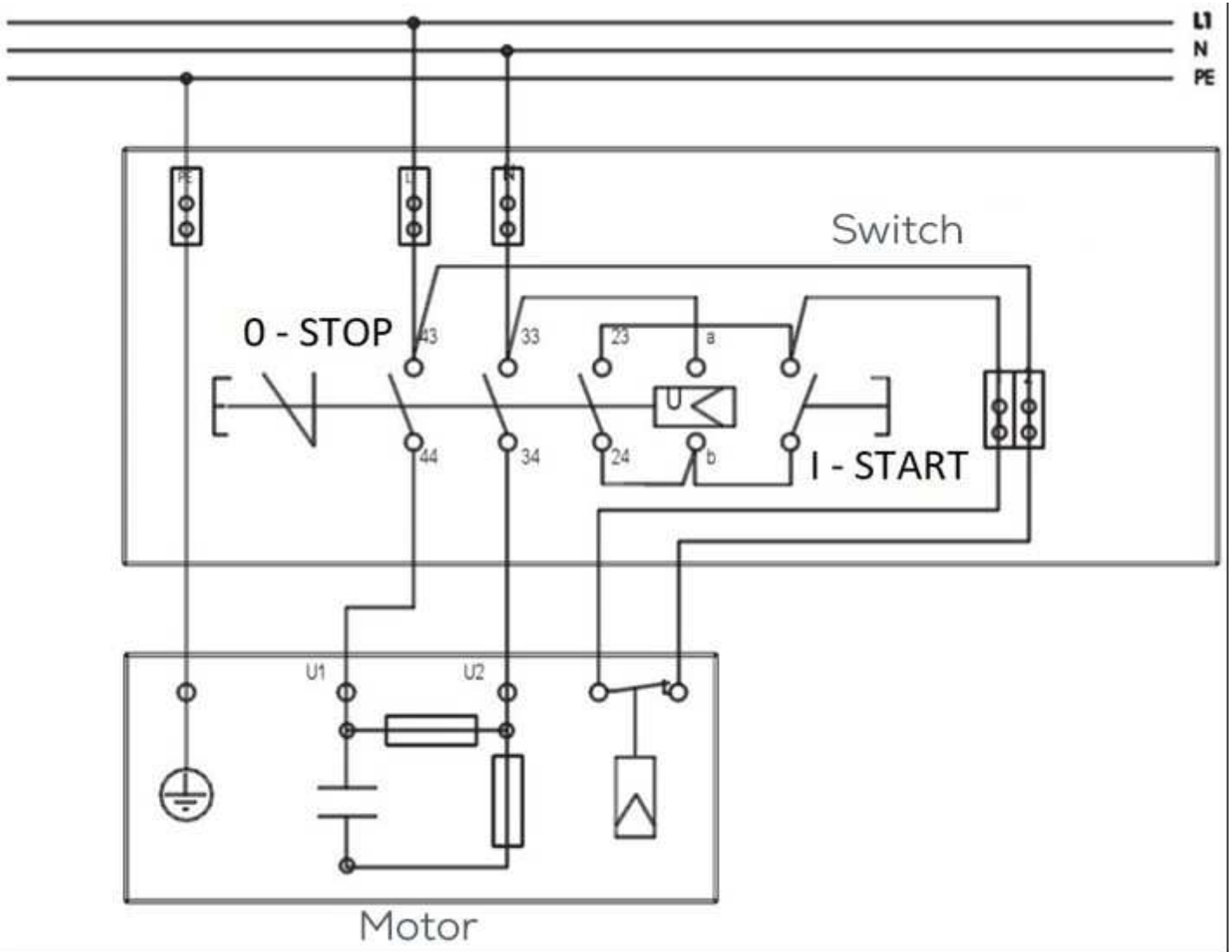

10 NOISE LEVEL

The noise level emitted by this machine during operation will depend on the type of material being ground and the type of bench grinder. For this reason, the measurement data is relative.

The risk of hearing damage to the operator depends on the length of exposure to noise.

The operator must wear ear defenders or other appropriate personal protective equipment when the sound power exceeds 85 dB(A) in the workplace.

- Average sound pressure level:
LpAm = 88.3 dB(A)
- Sound power level:
LwA = 103.4 dB(A)
- Sound pressure level at the workstation:
LpA = 90.7 dB(A)

The sound power was calculated taking into account factors such as: reverberation in the test area, sound absorption by the floor, and other factors that could interfere with the measurements. This estimate allows us to conclude that the margin of error for the values obtained is around 3 dB(A).

The values given are emission levels and not necessarily levels that allow for safe working. Although there are correlations between emission levels and exposure levels, these cannot be used reliably to determine whether additional precautions are necessary. Parameters that influence actual exposure levels include workshop characteristics, other sources of noise, etc., i.e., the number of machines and neighboring manufacturing processes. In addition, permissible exposure levels may vary from country to country. However, this information allows the machine user to make a better risk assessment.



11 VIBRATION LEVEL

The data relating to the vibrations transmitted by this machine during the work process will depend on the type of material being ground and the type of bench grinder. For this reason, the measurement data is relative.

Exposure to vibrations can have serious consequences for the health of workers. A person exposed daily to high-amplitude vibrations may develop neurological and joint disorders in the long term.

The exposure level assessment is based on the calculation of the daily exposure value A(8), normalized to a reference period of 8 hours.

Whenever an employee is exposed to A(8) vibrations exceeding the daily exposure level triggering action set at 2.5 m/s², the

These values must be taken into account when assessing the level of exposure.

Regular and frequent exposure to a highly vibrating work tool exposes workers' hands and arms to chronic disorders known as "vibration syndrome."

- Average hand/arm vibration level:
A(8) < 2.5 m/s²

employer must assess the risks of the task assigned to the employee and implement control measures.

Exposure values for vibrations transmitted to the hand-arm system:

- Daily exposure limit value A(8) = 5 m/s²
- Daily exposure action value A(8) = 2.5 m/s²

12 ENVIRONMENTAL PROTECTION

Your machine contains many recyclable materials.
This logo indicates that used machines must not be mixed with other waste.
This will ensure that the machines are recycled under the best conditions, in accordance with European Directive 2012/19/EU on waste electrical and electronic equipment.
Contact your local council or dealer to find out where your nearest collection points for used machines are located.
Thank you for your cooperation in protecting the environment.



13 WARRANTY

If the machine is covered by warranty, it must be serviced exclusively by an authorized after-sales service center.
The machine warranty is valid for 2 years from the date of purchase by the user.
This product benefits from an additional 2-year warranty extension, provided that the user registers the product on the PEUGEOT OUTILS PROFESSIONNELS website (www.peugeot.outils-pro.com) within 30 days of the date of purchase. This warranty extension is subject to the same conditions as the initial warranty.
Accessories and consumables are not covered by the warranty.
It is important to keep the invoice, which serves as the warranty certificate.
The warranty is limited to the repair or replacement of defective parts free of charge, after evaluation by the manufacturer.
For any requests for information or spare parts relating to the machine, it is essential to provide the exact information shown on the nameplate.
The warranty does not cover damage caused by the user or by a repairer not approved by Tivoly.

Link to the General Warranty Terms and Conditions:



CE AL DECLARATION OF CONFORMITY "ORIGINAL"

The undersigned (Manufacturer/Importer):

TIVOLY

266 ROUTE PORTES DE TARENTEISE 73790 TOURS-EN-SAVOIE

Declares that the following new machine:

- Designation: **GRINDING MACHINE**
- Brand: **PEUGEOT PROFESSIONAL TOOLS**
- Model: **PTMM150**
- Reference: **PPM00100001**
- Serial number:

Complies with applicable harmonized legislation:

- **Machinery Directive 2006/42/EC (until January 19, 2027)**
- **EU Regulation 2023/1230 (from January 20, 2027)**

Complies with the essential safety requirements applicable to it:

- **Low Voltage Directive 2014/35/EU**
- **Electromagnetic Compatibility Directive 2014/30/EU**
- **WEEE Directive 2012/19/EU**
- **RoHS-2 Directive 2011/65/EU**
- **REACH 1907/2006**
- **Noise Directive 2003/10/EC**
- **Vibration Directive 2002/44/EC**

Done at TOURS-EN-SAVOIE
On

Stéphane Le Mounier
Managing Director



Person authorized to compile the technical file:

- Mr. LE MOUNIER – TIVOLY – 266 ROUTE PORTES DE TARENTEISE 73790 TOURS-EN-SAVOIE

	TIVOLY: Registered office: 266 ROUTE PORTES DE TARENTEISE 73790 TOURS-EN-SAVOIE www.peugeot-outils-pro.com	USER SERVICE Tel: +33(0)4 79 89 59 00
	In its ongoing effort to improve the quality of its products, TIVOLY reserves the right to modify their characteristics. The information, photos, exploded views, and diagrams contained in this document are not contractual.	Published april 2026 Instruction manual PTMM150