



Get a free 2-year warranty



DE / GB / PT / SP

# WOOD CHIP VACUUM PAS1200M

IN GOOD HANDS

ORIGINAL INSTRUCTION MANUAL

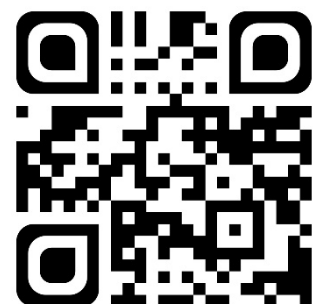



## ABOUT US

**Peugeot Professional Tools** was born out of several obvious reasons.

The obvious choice to combine the know-how of **Peugeot**, which has mastered the art of cutting since 1810, with the expertise of **Tivolys**, a metalworker since 1917, to create a wide range of machines and tools for construction and maintenance professionals.

It is also a commitment to serving craftsmen and small businesses driven by strong family and heritage values.

For these professionals, **Peugeot Outils Professionnels** offers machines and tools designed specifically to meet their needs. **These tools are reliable, durable, and serviceable in France** and in countries covered by distribution agreements, through local industrial and family-owned partners.

Trusted equipment, backed by a longer warranty, with logistics and

**French after-sales service.** The assurance of dealing with the very people who assembled these tools and know every component inside out.

From exceptional projects to everyday job sites, these tools are designed to withstand the most demanding conditions and stand the test of time.

**Peugeot Professional Tools** was born from one simple truth: that our tools are in good hands. The hands of those who work behind the scenes and give their all to satisfy their customers.

**Since 1810**, much has changed, but the hands have remained the same. The hands of passionate individuals, craftsmen, technicians, and dedicated installers—workers proud of themselves and their accomplishments.

**Peugeot Professional Tools: tools in good hands.**

## THANK YOU FOR YOUR PURCHASE.

We are delighted that you have chosen Peugeot Professional Tools. Every detail has been designed to provide you with an exceptional experience, and we hope you enjoy using it as much as we enjoyed creating it for you.

Your trust is essential to us, and we are delighted to support you every step of the way in your experience with the Peugeot Outils Professionnels brand.

**Your purchase comes with a 2-year warranty, extendable for an additional 2 years.**

**comments. To take advantage of this, sign up at [www.peugeot-outils-pro.com](http://www.peugeot-outils-pro.com)**

If you have any questions or need assistance, our team is here to provide you with the best possible service.

To contact our customer service department, visit [www.peugeot-outils-pro.com](http://www.peugeot-outils-pro.com), call [+33\(0\)4.79.89.59.00](tel:+330479895900), or email at [serviceclient@peugeot-outils-pro.com](mailto:serviceclient@peugeot-outils-pro.com)

Thank you for choosing Peugeot Professional Tools. Your satisfaction is our priority.

**TABLE OF CONTENTS**

<b>1</b>	<b>INTRODUCTION</b> .....	<b>4</b>
<b>2</b>	<b>PICTOGRAMS</b> .....	<b>4</b>
2.1	MACHINE SAFETY PICTOGRAMS .....	4
2.2	PICTOGRAMS IN THIS INSTRUCTION MANUAL .....	4
<b>3</b>	<b>SAFETY</b> .....	<b>5</b>
3.1	GENERAL SAFETY INSTRUCTIONS .....	5
3.2	SPECIFIC SAFETY REQUIREMENTS .....	6
3.3	OPERATOR PROTECTION .....	6
<b>4</b>	<b>DESCRIPTION AND OPERATION</b> .....	<b>7</b>
4.1	INTENDED USE OF THE MACHINE .....	7
4.2	SPECIFICATIONS .....	7
4.3	MACHINE DESCRIPTION .....	7
<b>5</b>	<b>INSTALLATION</b> .....	<b>8</b>
5.1	PACKAGING .....	8
5.2	MACHINE SETUP .....	8
5.3	ASSEMBLY .....	8
5.4	ELECTRICAL CONNECTION .....	11
<b>6</b>	<b>OPERATION</b> .....	<b>12</b>
<b>7</b>	<b>MAINTENANCE</b> .....	<b>13</b>
7.1	CLEANING THE FILTER .....	13
7.2	TROUBLESHOOTING TABLE .....	13
7.3	DESCRIPTION OF THE PICTOGRAMS USED ON THE MACHINE .....	14
<b>8</b>	<b>EXPLODED VIEW</b> .....	<b>15</b>
<b>9</b>	<b>ELECTRICAL DIAGRAM</b> .....	<b>17</b>
<b>10</b>	<b>NOISE LEVEL</b> .....	<b>18</b>
<b>11</b>	<b>VIBRATION LEVEL</b> .....	<b>18</b>
<b>12</b>	<b>ENVIRONMENTAL PROTECTION</b> .....	<b>19</b>
<b>13</b>	<b>WARRANTY</b> .....	<b>19</b>
<b>14</b>	<b>DECLARATION OF CONFORMITY</b> .....	<b>20</b>

## 1 INTRODUCTION



**For safety reasons, read this instruction manual carefully before using this machine. Failure to follow the instructions may result in injury to persons and/or damage to the machine.**

This instruction manual is intended for the operator, the setter, and the maintenance technician.

This instruction manual is an important part of your equipment. It provides rules and guidelines that will help you use this machine safely and effectively. You must familiarize yourself with the functions and operation by carefully reading this instruction manual. For your safety, it is particularly important that you read and follow all recommendations on the machine and in this instruction manual.

These recommendations must be strictly followed at all times during the operation and maintenance of the machine. Failure to follow the safety guidelines and warnings in the instruction manual and on the machine, and/or using the machine in a manner other than that recommended in the instruction manual, may result in machine failure and/or injury.

Please keep this instruction manual with the machine or in a location that is easily accessible at all times for future reference. Ensure that all personnel involved in the operation of this machine review it periodically.

If the instruction manual is lost or damaged, please contact us or your dealer to obtain a new copy.

Always use PEUGEOT OUTILS PROFESSIONNELS components and parts. Replacing components or parts with non-PEUGEOT OUTILS PROFESSIONNELS items may cause damage to the machine and endanger the operator.

This manual describes the safety instructions that the user must follow. Pursuant to Article L.4122-1 of the Labor Code, it is the responsibility of the employer or the user to ensure their own health and safety, as well as that of others affected by their actions or omissions, in accordance, in particular, with the instructions provided to them.

The employer must conduct an assessment of the specific risks associated with their activity, must train workers on the machine and on the prevention of these risks, and must appropriately inform workers responsible for the use or maintenance of work equipment of the instructions or guidelines applicable to them.

## 2 PICTOGRAMMES

### 2.1 MACHINE SAFETY PICTOGRAMS

Meaning of the safety symbols affixed to the machine (keep them clean and replace them if they are illegible or peeling off):



Safety glasses must be worn



Hearing protection must be worn



Protective clothing must be worn



Safety shoes must be worn



Read the instruction manual carefully



Do not touch



Danger: electrical hazard

### 2.2 PICTOGRAMS IN THIS INSTRUCTION MANUAL



Immediate danger to persons and damage to the machine



Possible damage to the machine or its surroundings



When changing tools or cleaning, wear protective gloves



Note



**Electrical work must be performed by qualified personnel authorized to perform low-voltage electrical work.**

### 3 SÉCURITÉ

#### 3.1 GENERAL SAFETY REQUIREMENTS



**To reduce the risk of fire, electric shock, mechanical injury, and personal injury when using power tools, follow the basic safety guidelines.**

These operating instructions take into account only reasonably foreseeable conditions.

Our machines are designed and manufactured with the operator's safety always in mind.

We assume no liability for any damage resulting from inexperience, improper use of the machine, and/or damage to the machine, and/or failure to comply with the instructions and safety rules contained in this instruction manual.

As a general rule, accidents always occur as a result of improper use or failure to read the instruction manual.

Please note that any modification to the machine will void our warranty.

Check that all safety guards are present, in good condition, and functioning properly before starting work.

Ensure that moving parts are functioning properly, that there are no damaged components, and that the machine operates perfectly during startup.

Only qualified and authorized personnel are permitted to repair or replace damaged parts.

Keep the work area clean and tidy.

Ensure that the entire work area is visible from the workstation.

Cluttered work areas and workbenches are a potential source of injury.

Do not use the machine outdoors, in very damp areas, or in the presence of flammable liquids or gases.

Place the machine in a sufficiently lit work area.

The machine is prohibited for use by young workers under the age of eighteen.

Do not allow anyone, especially children or animals, who are not authorized to be in the work area to touch the tools or electrical cables, and keep them away from the work area.

Never leave the machine unattended while it is running. Always disconnect the power supply. Only leave the machine when it has come to a complete stop.



Do not force the tool; it will perform better and be safer when operated at the speed for which it is designed.

Do not use small tools to perform work intended for a larger tool.

Do not use tools for tasks for which they are not intended.



Do not damage the power cord.

Never pull on the power cord to unplug it from the electrical outlet.

Keep the power cord away from heat sources, greasy surfaces, and/or sharp edges.

Protect the power cord from moisture and any potential damage.

Check the power cord periodically, and if it is damaged, have it repaired by an authorized service technician.

A defective switch must be replaced by an authorized service provider.

Do not use the machine if the switch does not turn it on or off.



Do not overestimate your strength.

Always maintain a stable position and good balance.

Pay attention to what you are doing, use common sense, and do not operate the machine when you are tired.

Always use both hands when operating this machine.

The use of any accessories other than those described in the instruction manual may pose a risk of injury to people.

The user is responsible for the machine and must ensure that:

The reel is used by people who are familiar with the instructions and authorized to do so.

Safety rules have been followed.

Users have been informed of the safety rules. Users have read and understood the instruction manual.

Responsibilities for maintenance and any necessary repairs have been clearly assigned and followed. Any defects or malfunctions have been immediately reported to an authorized repair technician or your dealer.

The reel must be used for the applications described in this manual.

Any use other than that specified in this instruction manual may be hazardous.

Mechanical and/or electrical safety devices must not be removed or bypassed.

No modifications and/or conversions may be made.

PEUGEOT OUTILS PROFESSIONNELS disclaims all liability for damage caused to persons, animals, or property resulting from failure to comply with the instructions and safety rules contained in this manual

### 3.2 SPECIFIC SAFETY REQUIREMENTS

- Before use, check that the machine is not damaged. Do not use the machine if any parts are damaged.
- Before starting the machine, make sure there are no objects (such as tools) inside the machine.
- Turn off the machine and unplug it when not in use.
- Never use damaged chip bags.
- Use only new chip bags. Do not reuse used chip bags.
- Before starting the machine, check that the dust collection unit is unobstructed and clean
- Wear gloves during any maintenance or cleaning operation.
- Dust and wood chips are hazardous to your health and should never be inhaled. Always wear a mask when cleaning the machine.
- Do not submerge the machine in water or wash it with a high-pressure water jet, as this may cause water to enter the electrical components.
- Do not use solvents or harsh detergents.
- Store the machine in a dry place and out of the reach of children.

### 3.3 OPERATOR PROTECTION



**For the operator's safety, ensure that protective screens and guards are in good condition and are in place. Ensure that non-working parts are always covered by a protective guard.**

This machine is designed for a single operator.

The operator must wear appropriate personal protective equipment:

- Safety goggles.
- Hearing protection.
- Safety shoes.
- Respiratory protection.

The operator must wear close-fitting clothing and, if necessary, a hairnet for long hair.

The operator must not wear, for example:

- Loose-fitting clothing or clothing with wide sleeves.
- Bracelets, watches, wedding rings, or jewelry.
- Any other object that could get caught in the machine's moving parts.



## 4 DESCRIPTIF ET FONCTIONNEMENT

### 4.1 INTENDED USE OF THE MACHINE

The PAS1200L is a machine designed for the extraction of chips and dust produced during the processing of wood or similar materials. Machining of any material other than wood is permitted only with the manufacturer's approval.

In the event of misuse or the extraction of materials other than those mentioned above, the manufacturer shall not be held liable.

Under proper operating and maintenance conditions, safe operation and performance are guaranteed for several years. To ensure this, familiarize yourself with the machine's various functions.

### 4.2 SPECIFICATIONS

- Lightweight, mobile unit with a compact footprint in the workshop
- Suction capacity of 1200 m<sup>3</sup>/h
- Cartridge filter with manual cleaning
- Dust and chips fall directly into the collection bag
- Transparent plastic collection bag with quick-release fastener
- Balanced steel impeller
- Sturdy steel frame for increased rigidity
- Steel base with 4 casters

	Airflow (m <sup>3</sup> /h)	Vacuum (kPa)	Chip bag volume (L)	Diameter Connection (mm)	Power supply	Motor (kW)	Weight (kg)	Dimensions (W x D x H) (mm)
<b>PAS1200L</b>	1200	1.9	153	125	230V – single-phase	1.5	47	1000 x 750 x 2000

### 4.3 MACHINE DESCRIPTION

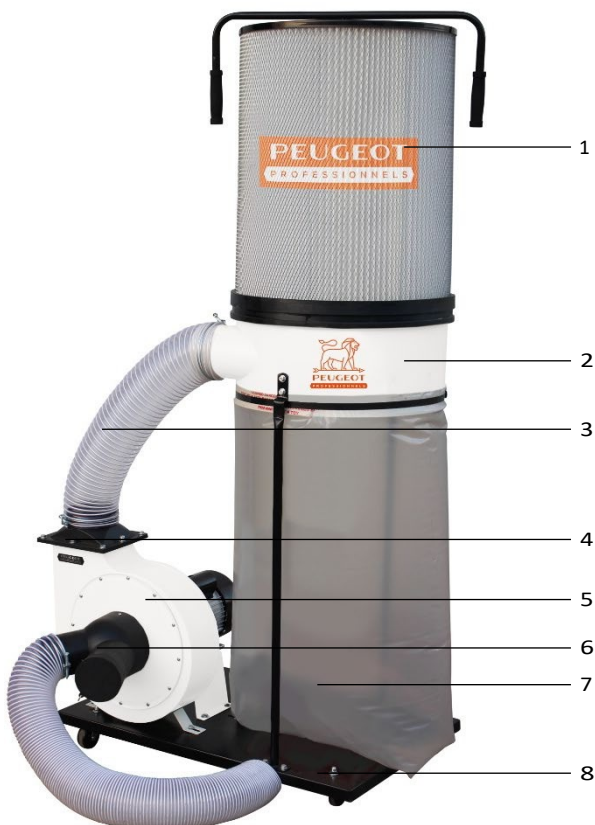

1. Filter cartridge
2. Central support
3. Connection hose
4. Connection plate
5. Impeller housing
6. Inlet fitting
7. Chip bag
8. Base

## 5 INSTALLATION

### 5.1 PACKAGING

The machine is packaged in a cardboard box with polystyrene padding.

When unpacking, remove each part, check its overall condition, and then proceed with assembly.

If the product appears to be defective or if any parts are broken or missing, contact your seller.

Keep the instruction manual for future reference.

### 5.2 SETTING UP THE MACHINE



#### Installation environment:

- Power supply Electrical in accordance machine specifications (230V single-phase).
- Ambient temperature between +5°C and +40°C.
- Relative humidity not exceeding 90%.
- Adequate ventilation at the installation site.
- A work area that is sufficiently lit to ensure safety: lighting must be 500 LUX.

### 5.3 ASSEMBLY

1. Install the 4 casters (J) under the base using the screws and washers

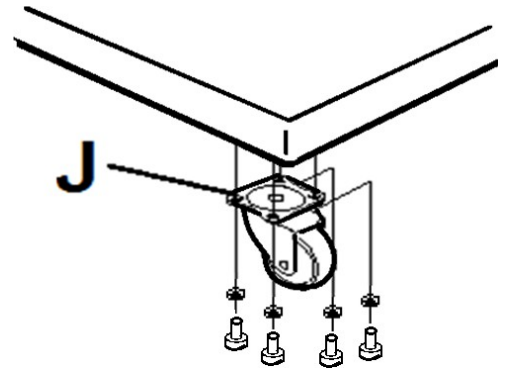

2. Attach the motor base (L) to the motor and turbine assembly (S, B)
3. Attach the assembly to the base (D)

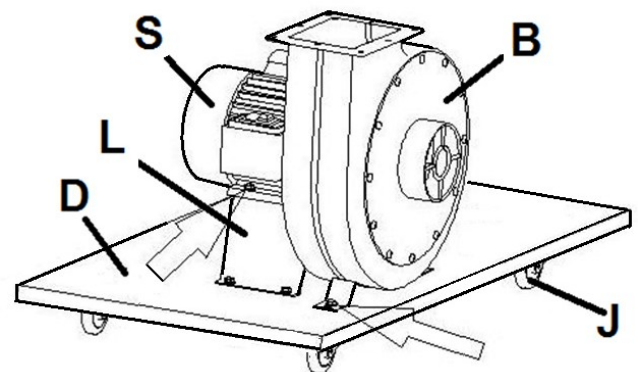

4. Place the gasket (I) on the turbine (B)
5. Place the connection plate (W) on the gasket, then secure the assembly using the provided screws

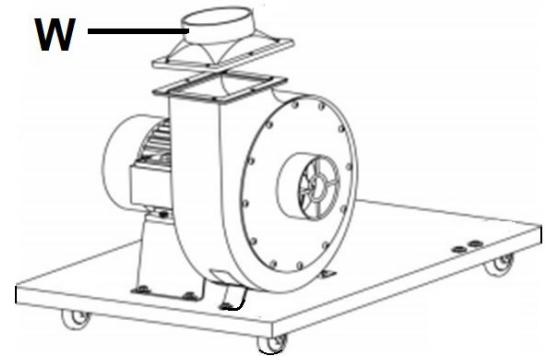
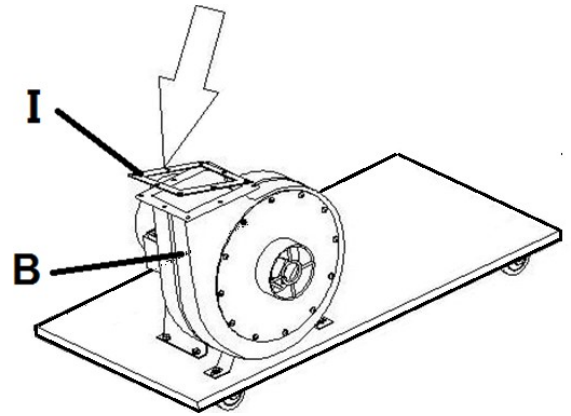

6. Attach the 3 support tubes (F) to the base using the screws and washers

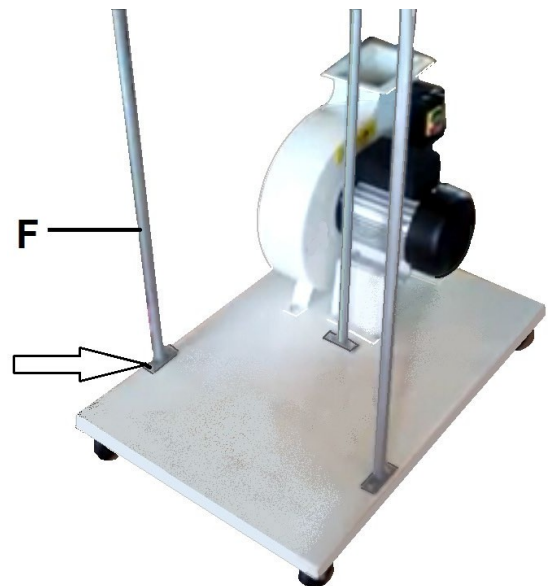

7. Attach the central bracket (C) to the support tubes (F)
8. Attach the filter bag support tube to the central support (C)

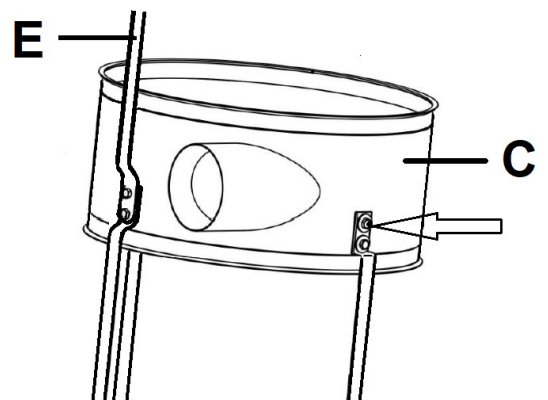

9. Slide the clamps onto each side of the hose and tighten them
10. Insert the hose into the connection plate (W) and tighten the clamp
11. Insert the hose into the central bracket (C) and tighten the clamp

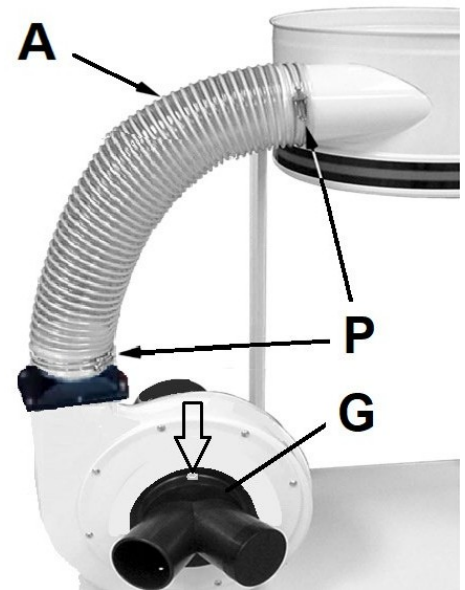

12. Install the handle (I) using the screw (J) and washer (H)
13. Place the cartridge filter on the central support (C)
14. Place the clamp (N) around the cartridge filter and tighten it until the cartridge is securely fastened

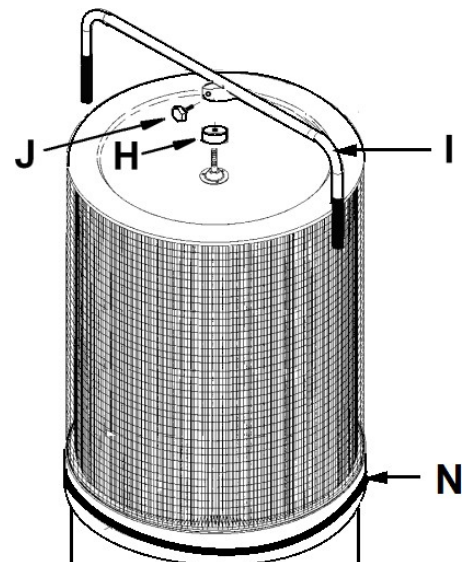

15. Slide the chip bag (Q) onto the central support (C)
16. Place the clamp (N) around the bag and tighten it until the bag (Q) is securely fastened

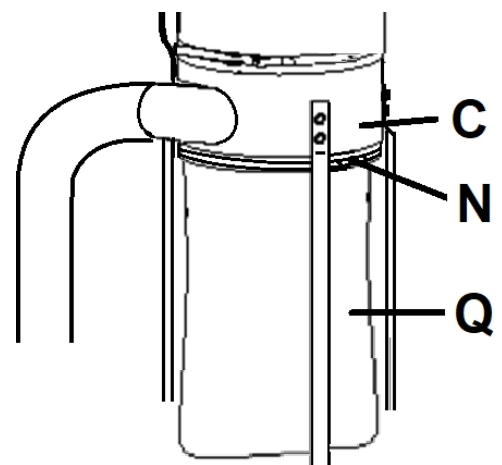

The bags must be securely fastened to the central support to ensure a tight seal and prevent dust or chips from escaping

It is essential to ground the suction hoses to prevent them from becoming charged with static electricity and causing sparks.

After securing the suction hose (O) to the machine using a hose clamp (P), connect it to ground:

1. Attach the grounding cable (PE) to the motor housing if it is not already secured
2. Strip the suction hose (O) until a wire from the metal reinforcement is visible
3. Connect an electrical terminal block to the metal reinforcement of the suction hose
4. Connect the ground wire to the terminal block

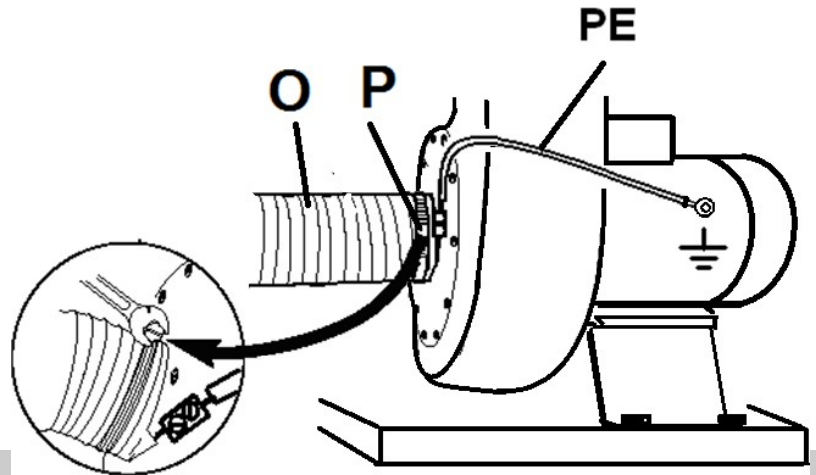

**Always use conductive, fire-resistant suction hoses and**

#### 5.4 ELECTRICAL CONNECTION



**Electrical work must be performed by qualified personnel authorized to perform low-voltage electrical work.**



**Check that the cutting shaft is rotating in the correct direction.  
The warranty does not cover damage caused by an improper connection.**



#### ELECTRICAL CONNECTION

Ensure that the mains voltage matches that of the machine and that the electrical outlet is in good condition and properly grounded. Check that the electrical outlet at your location is compatible with the machine's power cord plug.

The electrical outlet must comply with the "EN 60309-1" standards.

Connect the machine using the power cord.

Ensure that the machine's power switch is in the "0" position. Verify that the electrical system to which the machine will be connected is properly grounded in accordance with current safety standards.

We remind the user that there must always be a circuit breaker upstream of the electrical installation to protect all conductors against short circuits and overloads.

This protection must always be selected based on the machine's electrical specifications, as indicated on the nameplate:

- Voltage: 230 V three-phase
- Frequency: 50 Hz
- Current: 7.3 A
- Motor power: 1.5 kW

For the PAS1200M, the fuse rating must be 10A.



**Use cables and reels with a cross-section and length appropriate for the machine's power rating, and unroll them completely.  
Electrical connectors and extension cords must be protected from splashes and kept on dry surfaces.**



**Using the machine with a damaged power cord is strictly prohibited. Regularly check the condition of the power cord, the cable gland, and the switch.**



**Do not unplug the power cord by pulling on the power cord; pull only on the plug.**

## 6 UTILISATION



**Never start the machine if no hose is connected**

**Do not use the machine as a vacuum cleaner. Vacuuming materials other than wood (such as metal debris) can damage the fan or the bags**

To start the machine, press the green start button. To turn off the machine, press the red stop button

Operating instructions:

1. Check that the suction hose is properly connected to the machine
2. Check that the chip bag is securely fastened
3. Start the chip vacuum by pressing the start button
4. Then start the machining machine
5. After finishing work on the machine tool, turn it off first
6. Then turn off the chip vacuum

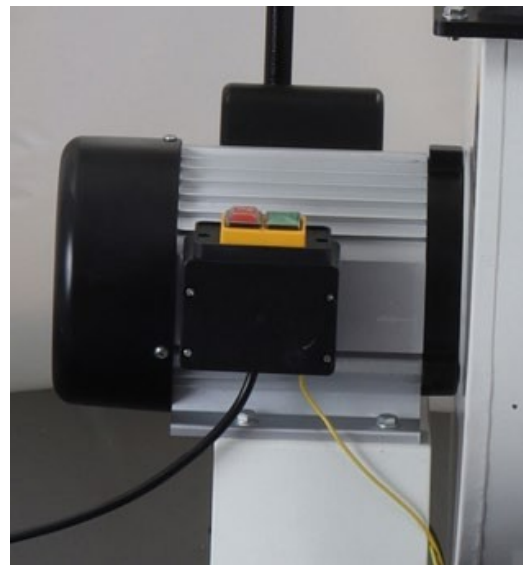

**Check regularly to make sure the chip bag is not full before starting the chip vacuum**

**When using a planer with blades:**

Regularly check the chip inlet on the vacuum. Since the vacuum is equipped with a cross-shaped inlet, and the chips from a planer are long and thin, they tend to form a clog

The cross-shaped guide can be removed; it is simply glued to the fitting



## 7 MAINTENANCE



**Disconnect the power supply before performing any maintenance or servicing. Wear gloves and safety goggles**

To maintain the efficiency of the machine and its components, it is necessary to perform maintenance.

Below are the most important maintenance procedures.

Failure to perform the prescribed tasks leads to premature wear and reduces the machine's performance.

Before performing any maintenance, it is essential to disconnect the machine from the power supply to prevent accidental startup.



### 7.1 CLEANING THE FILTER

The filter must be cleaned regularly to ensure proper airflow

To clean the filter, turn the handle attached to it to clear any clogs



**Always wear a mask during cleaning operations**

### 7.2 TROUBLESHOOTING TABLE

Faults	Solutions
The machine does not start	Check the electrical connection
	Check the motor or switch. If they are defective, contact your supplier
Significant vibrations	Check all machine components and tighten all screws The motor mount may be damaged; if so, replace it The motor bearing needs to be replaced
The suction is weak	Empty the chip bag. Clean the filter Reduce the size of the exhaust hose

### 7.3 DESCRIPTION OF THE PICTOGRAMS USED ON THE MACHINE

---

#### A. Nameplate



: Motor specifications: power, voltage, frequency, amperage



: Machine weight



: Airflow



: Chip bag capacity



Suction nozzle diameter

**IP 54**

: Machine protection rating

#### B. Maintenance



: Maintenance instructions

## 8 VUE ÉCLATÉE

EXPLODED VIEW PAS1200M (VIEW 01)

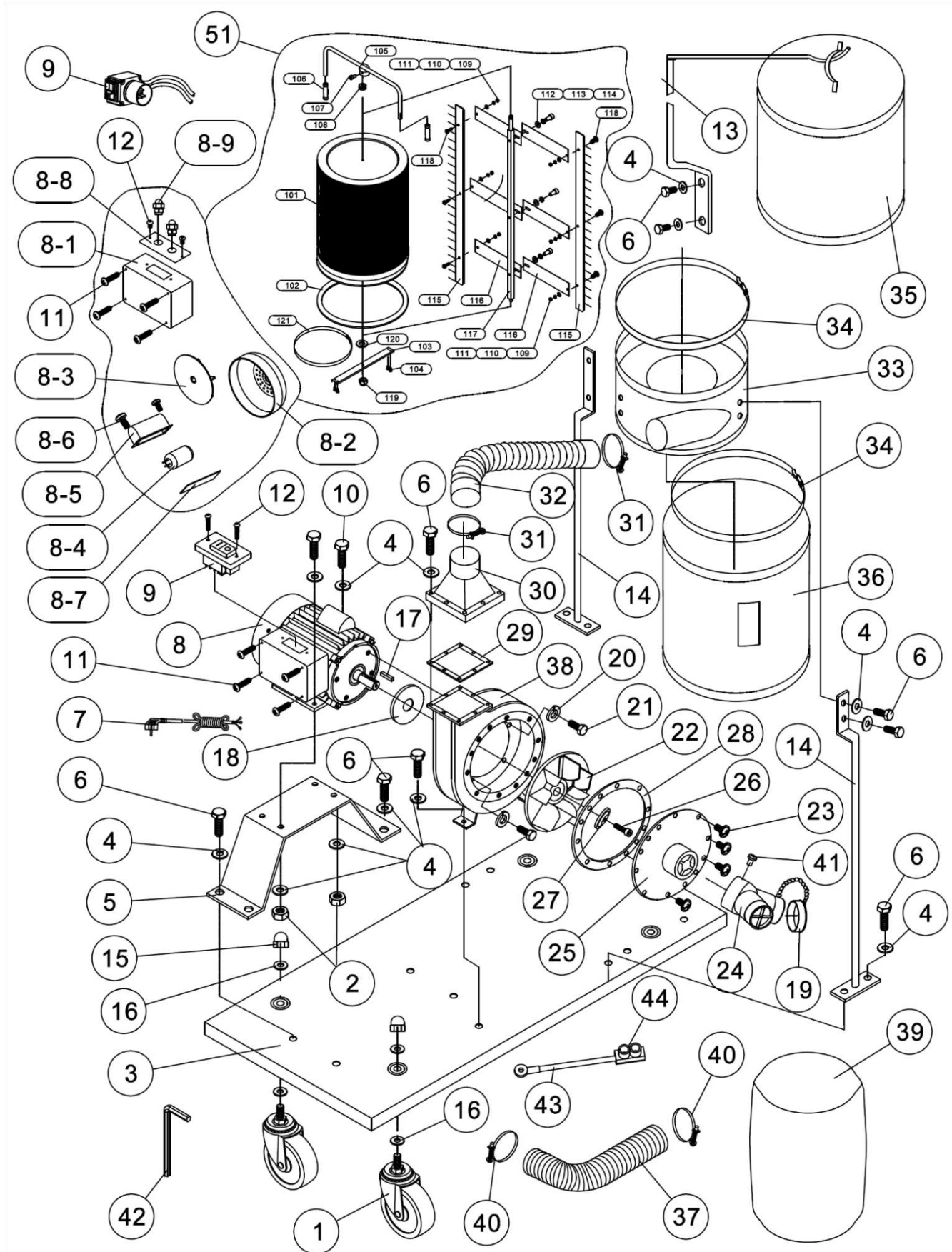

## PARTS LIST FOR EXPLODED VIEW PAS1200M (VIEW 01)

Part Number	Description	Quantity
1	2.5" casters	4
2	M8 hex nut	4
3	Base	1
4	Flat washer 8	28
5	Motor mount	1
6	M8x16 hex bolt	12
7	230V 50Hz 1-phase cable and plug	1
8	Motor assembly	1
8-1	Switch housing	1
8-2	Motor cover	1
8-3	Motor fan	1
8-4	450V 50µF capacitor	1
8-5	Capacitor cover	1
8-6	Screw for capacitor cover M5x10	2
8-7	Rubber washer for motor	1
8-8	400V switch housing plate	1
8-9	Cable gland (400V)	1
9	230V 50Hz 1-phase switch	1
10	M8x25 hex bolt	4
11	M4x60 pan head screw	4
12	ST4.2x12 self-tapping pan head screw	2
13	Upper bag support	1
14	Collector bracket	2
15	M8 cap nut	4
16	Flat washer 8	16
17	Key 5x5x20	1
18	Packing / packaging	1
19	Inlet cover	1
20	Lock washer 10	4
21	M10x25 hex bolt	4
22	Turbine (turbo fan)	1
23	M6x10 pan-head screw	12
24	Y-shaped inlet (No. 19 & No. 41)	1
25	Entry form	1
26	A5x25 key	1
27	CHC Screw M6x20 Left	1
28	Spacer A	1
29	Spacer B	1
30	Output	1
31	125 mm clamp	2
32	5" Hose Ø125x750mm	1
33	Manifold	1
34	Clamp	2
35	Filter bag (30 µm)	1
36	Collection bag (30 µm)	1
37	4" x 2 mm hose, Ø100x2000mm	1
38	Turbine housing	1
39	Collection bag (plastic)	2
40	Clamp Ø100 mm	2
41	M5x8 pan head screw	1
42	Hex wrench S=5	1
43	Cable connector	1
44	Electric wire	1
51	Filter cartridge 20/24 (No. 101 to 119)	1
101	Filter assembly (includes No. 102)	1
102	Rubber cushion	1
103	Bracket	1
104	ST4.8x16 self-tapping screw	4
105	Handle	1
106	Soft handle	2
107	M6x10 CHC screw (cylindrical head with hexagonal socket)	1
108	Ball bearing 6201	1

109	M5 hex nut	6
110	Lock washer 5	6
111	Flat washer 5	6
112	CHC screw M6x12	3
113	Lock washer 6	3
114	Flat washer 6	3
115	Scraper	2
116	Pressure plate	6
117	Shaft	1
118	M5x12 pan-head screw	6
119	M12 lock nut	1
120	Flat washer 12	1
121	Clamp	1

## 9 SCHÉMA ÉLECTRIQUE

## ELECTRICAL DIAGRAM PAS1200M

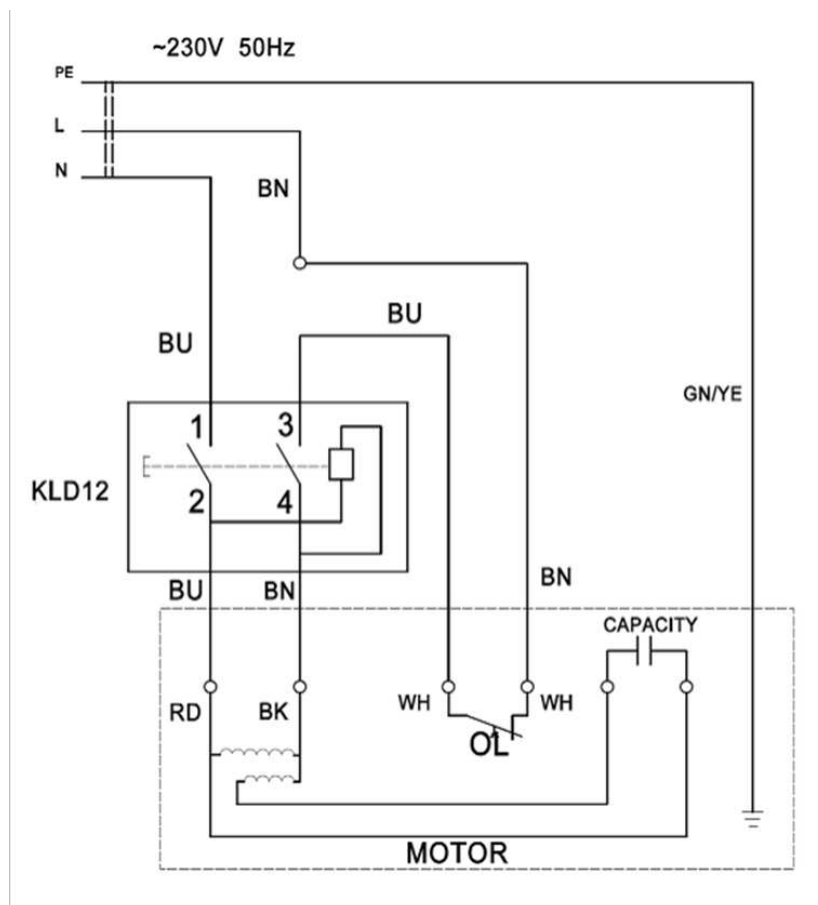

Part No.	Designation
BK	Black
WH	White
BU	Blue
BN	Brown
YE	Yellow
RD	Red
GNYE	Yellow-green
M	Motor
S	Switch
C	Capacitor
OL	Overload trip

## 10 NIVEAU SONORE

The noise level data for this machine during operation will depend on the type of material being ground and the type of grinding wheel. For this reason, the measurement data are relative.

The risk of hearing damage to the operator depends on the duration of exposure to noise.

The operator must wear ear protection or other appropriate personal protective equipment when the sound power level exceeds 85 dB(A) at the workplace.

- Average sound pressure level:  
**LpAm = 80 dB(A)**

The acoustic power calculation was performed taking into account factors such as: reverberation in the test location, noise absorption by the floor, and other factors that may interfere with the measurements. This estimate indicates that, based on the obtained values, the margin of error is approximately 3 dB(A).

The values provided are emission levels and do not necessarily represent safe working levels. Although there are correlations between emission levels and exposure levels, these cannot be reliably used to determine whether additional precautions are necessary. Factors influencing actual exposure levels include workshop characteristics, other noise sources, etc., such as the number of nearby machines and manufacturing processes. Furthermore, permissible exposure limits may vary from country to country. However, this information allows the machine operator to make a better risk assessment.



## 11 NIVEAU VIBRATIONS

The vibration data transmitted by this machine during operation will depend on the type of material being ground and the type of grinding wheel. For this reason, the measurement data are relative.

Exposure to vibrations can have serious consequences for a worker's health. A person exposed daily to high-amplitude vibrations may develop neurological and joint disorders over the long term. These factors must be taken into account when assessing the level of exposure.

Regular and frequent exposure to a highly vibrating work tool exposes workers' hands and arms to chronic disorders known as "vibration syndrome."

- Average hand/arm vibration level:  
**A(8) < 2.5 m/s<sup>2</sup>**

The assessment of the exposure level is based on the calculation of the daily exposure value A(8), normalized to an 8-hour reference period.

Whenever an employee is exposed to A(8) vibrations exceeding the daily exposure action level of 2.5 m/s<sup>2</sup>, the employer must assess the risks of the task assigned to the employee and implement control measures.

Exposure values for vibrations transmitted to the hand-arm system:

- Daily exposure limit value A(8) = 5 m/s<sup>2</sup>
- Daily exposure action value A(8) = 2.5 m/s<sup>2</sup>



## 12 PROTECTION DE L'ENVIRONNEMENT

Your machine contains many recyclable materials.

This logo indicates that used machines must not be mixed with other waste.

This ensures that the machines are recycled under optimal conditions, in accordance with the European Directive 2012/19/EU on waste electrical and electronic equipment (WEEE).

Contact your local city hall or your dealer to find out where the nearest collection points for used machines are located.

Thank you for your cooperation in protecting the environment.



## 13 GARANTIE

If the machine is covered under warranty, repairs must be performed exclusively by an authorized service center. The machine's warranty is valid for 2 years from the date of purchase by the user.

This product is eligible for a 2-year warranty extension, provided that the user registers the product on the PEUGEOT OUTILS PROFESSIONNELS website ([www.peugeot.outils-pro.com](http://www.peugeot.outils-pro.com)) within 30 days of the purchase date. This warranty extension is subject to the same terms and conditions as the original warranty.

Accessories and consumables are not covered by the warranty.

It is important to keep the receipt, which serves as the warranty certificate.

The warranty is limited to the free repair or replacement of defective parts, following evaluation by the manufacturer.

For any requests for information or spare parts related to the machine, it is essential to provide the exact information listed on the nameplate.

The warranty does not cover damage caused by the user or by a repair technician not authorized by Tivoly.

Link to the General Warranty Terms and Conditions:



# CE AL DECLARATION OF CONFORMITY "ORIGINAL"

The undersigned (Manufacturer/Importer):

**TIVOLY**

**266 ROUTE PORTES DE TARENTEISE 73790 TOURS-EN-SAVOIE**

Declares that the following new machine:

- Description: **CHIP VACUUM**
- Brand: **PEUGEOT PROFESSIONAL TOOLS**
- Model: **PAS1200M**
- Part Number: **PPM01000002**
- Serial No.:

Complies with the applicable harmonized legislation:

- **Machinery Directive 2006/42/EC (until January 19, 2027)**
- **EU Regulation 2023/1230 (effective January 20, 2027)**
- **Woodworking machinery safety standard EN ISO 19085-1**

Complies with the applicable essential safety requirements:

- **Low Voltage Directive 2014/35/EU**
- **Electromagnetic Compatibility Directive 2014/30/EU**
- **WEEE Directive 2012/19/EU**
- **RoHS-2 Directive 2011/65/EU**
- **REACH 1907/2006**
- **Noise Directive 2003/10/EC**
- **Vibration Directive 2002/44/EC**

Done at TOURS-EN-SAVOIE  
The

Stéphane Le Mounier,  
General Manager



Person authorized to compile the technical file:

- Mr. LE MOUNIER – TIVOLY – 266 ROUTE PORTES DE TARENTEISE 73790 TOURS-EN-SAVOIE

	TIVOLY: Headquarters: 266 ROUTE PORTES DE TARENTEISE 73790 TOURS-EN-SAVOIE www.peugeot-outils-pro.com	CUSTOMER SERVICE Tel: +33(0)4 79 89 59 00
	In its ongoing effort to improve the quality of its products, TIVOLY reserves the right to modify their specifications. The information, photos, exploded views, and diagrams contained in this document are not binding.	November 2025 Edition Manual PAS1200M